



**INSTALLATION
AND
USER MANUAL**

INVERTER SWIMMING POOL HEAT PUMP



Content

I.	Application.....	2
II.	Features	2
III.	Technical Parameter	3
IV.	Dimension	4
V.	Installation instruction.....	5
VI.	Operation instruction.....	9
VII.	Testing.....	12
VIII.	Precautions.....	13
IX.	Maintenance.....	15
X.	Trouble shooting for common faults.....	16
XI.	Appendix: Heating priority (Optional).....	18

Thank your choosing our product and your trust in our company. To help you get maximum pleasure from using this product, please read this instruction manual carefully and operate strictly according to the user manual before starting the machine, otherwise the machine may be damaged or cause you unnecessary harm.

I. Application

- 1- Set swimming pool water temp efficiently and economically to provide you comfort and pleasure.
- 2- User may choose the model technical parameter according to professional guide, this series of swimming pool heater has been optimized in factory (refer to technical parameter table).

II. Features

- 1- High efficient titanium heat exchanger.
- 2- Sensitive and accurate temp control and water temp display.
- 3- High pressure and low pressure protection.
- 4- Exceeding low temp auto stop protection.
- 5- Temp control compulsory defrosting.
- 6- International brand compressor.
- 7- Easy installation and operation.

III. Technical Parameter

Model	PRO-07	PRO-09	PRO-13	PRO-17
Advised pool volume (m ³)	15~30	20~40	30~60	35~70
Operating air temperature (°C)	0~43			
Performance				
Heating capacity (kW)	7.0~1.8	9.2~2.0	12.5~2.8	16.5~3.5
Heating capacity (kW) in silence mode	5.6~1.8	7.5~2.0	10.0~2.8	13.3~3.5
Rated input power at air 15°C (kW)	1.3~0.19	1.7~0.21	2.3~0.3	2.9~0.36
Rated input current at air 15°C (A)	5.6~0.83	7.4~0.91	10~1.3	12.6~1.6
Max input current (A)	7.5	9.0	11.0	15.0
Power supply	230V/1 Ph/50Hz			
Advised water flux (m ³ /h)	2~4	3~4	4~6	6~8
Water pipe in-out Spec (mm)	50			
Net Dimension LxWxH (mm)	864x349x648	864x349x648	864x349x648	954x349x648
Net Weight (kg)	46	47	49	60

Notice:

1. This product can work well under air temp 0°C ~ +43°C, efficiency will not be guaranteed out of this range. Please take into consideration that the pool heater performance and parameters are different under various conditions.
2. Related parameters are subject to adjustment periodically for technical improvement without further notice. For details please refer to nameplate.

IV. Dimension

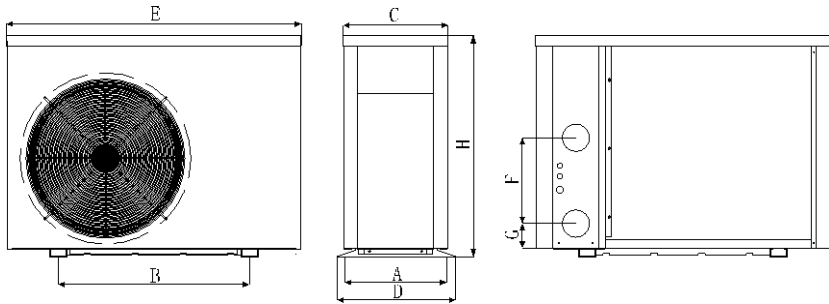

Size(mm) Name Model	A	B	C	D	E	F	G	H
PRO-07	324	560	308	349	864	250	73	648
PRO-09	324	560	308	349	864	250	73	648
PRO-13	324	560	308	349	864	290	73	648
PRO-17	324	590	308	349	954	350	73	648

※ Above data is subject to modification without notice.

Note:

The picture above is the specification diagram of the pool heater, for technician's installation and layout reference only. The product is subject to adjustment periodically for improvement without further notice.

V. Installation instruction

1. Drawing for water pipes connection

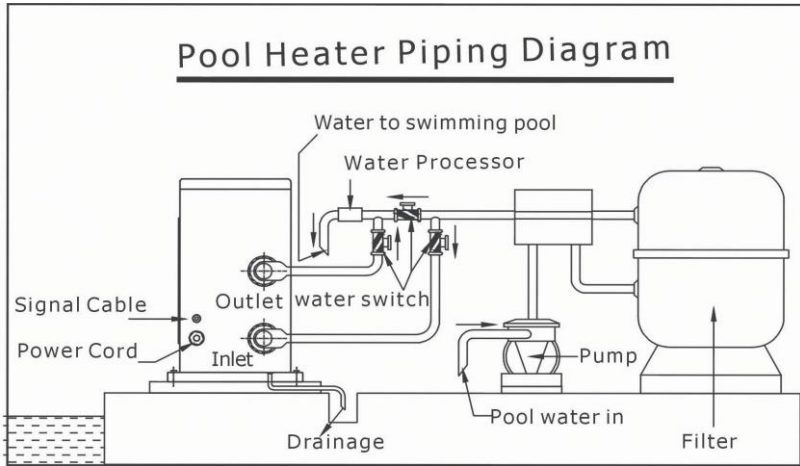

(Notice: The drawing is just for demonstration, and layout of the pipes is only for reference.)

2. Connecting your power wire

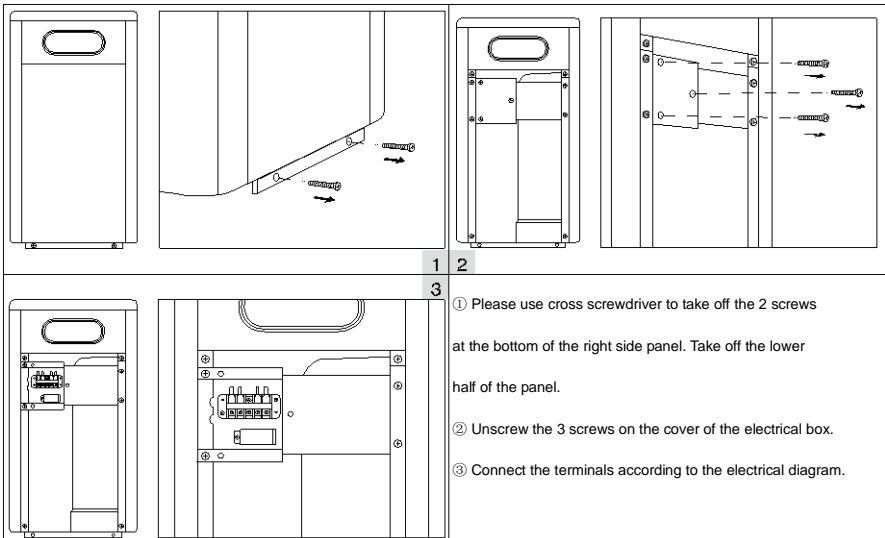

Note: please open the back panel for power connection. The operation is the same as above.

A.For power supply: 230V 50Hz

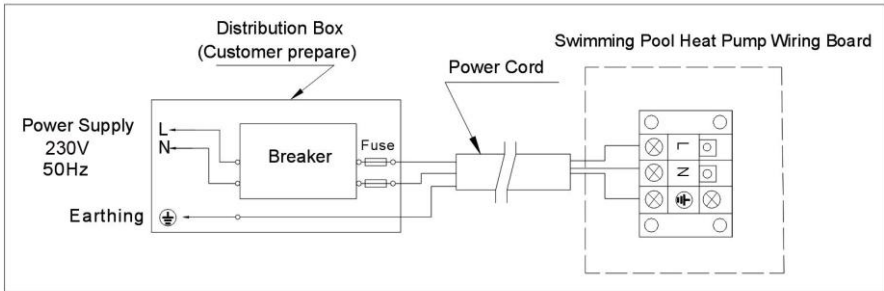

Note: The swimming pool heater must be earthed well.

3. Electric Wiring Diagram

Options for protecting devices and cable specification

MODEL		PRO-07	PRO-09	PRO-13	PRO17
Breaker	Rated Current A	9.0	11.0	13.5	18.0
	Rated Residual Action Current mA	30	30	30	30
Fuse	A	9.0	11.0	13.5	18.0
Power Cord	(mm ²)	3×1.5	3×2.5	3×2.5	3×2.5
Signal cable	(mm ²)	3×0.5	3×0.5	3×0.5	3×0.5

※ Above data is subject to modification without notice.

Note: The above data is adapted to power cord ≤ 10m. If power cord is >10m, wire diameter must be increased. The signal cable can be extended to 50m at most.

4. Installation instruction and requirement

The heat pump must be installed by a professional team. The users are not qualified to install by themselves, otherwise the heat pump might be damaged and risky for users' safety.

A. Installation

1) The inlet and outlet water unions can't bear the weight of soft pipes. The heat pump must be connected with hard pipes!

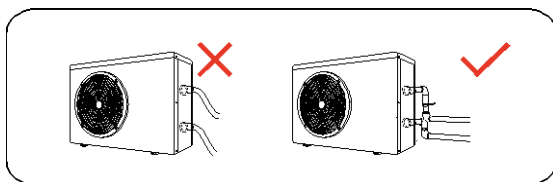

2) In order to guarantee the heating efficiency, the water pipe length should be $\leq 10\text{m}$ between the pool and the heat pump.

B. Installation instruction

1) Location and size

 The heat pump should be installed in a place with good ventilation

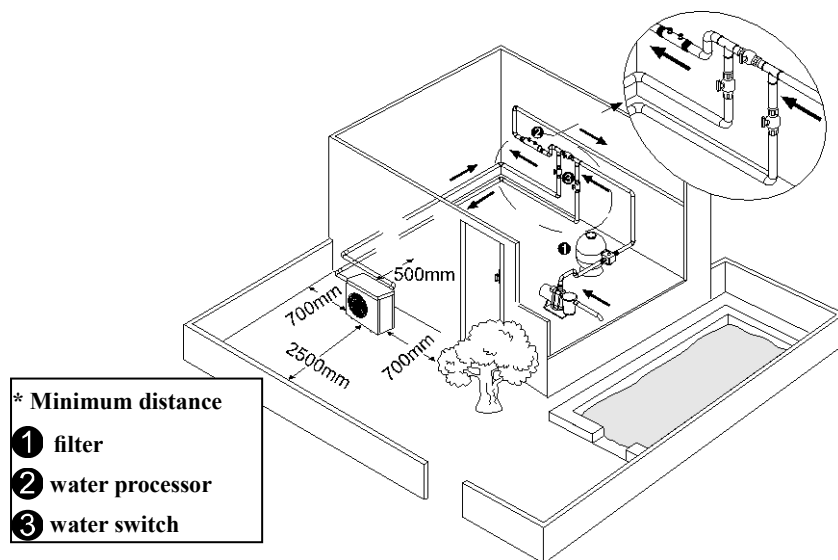

2) The frame must be fixed by bolts (M10) to concrete foundation or brackets. The concrete foundation must be solid and fastened; the bracket must be strong enough antirust treated;

3) Please don't stack substances that will block air flow near inlet or outlet area, and there is no barrier within 50cm behind the main machine, or the efficiency of the heater will be reduced or even stopped;

4) The machine needs an appended pump (Supplied by the user). The recommended pump specification-flux: refer to Technical Parameter, Max. lift $\geq 10\text{m}$;

5) When the machine is running, there will be condensation water discharged from the bottom, please pay attention to it. Please hold the drainage nozzle (accessory) into the hole and clip it well, and then connect a pipe to drain the condensation water out.



C. Wiring

- 1) Connect to appropriate power supply, the voltage should comply with the rated voltage of the products.
- 2) Earth the machine well.
- 3) Wiring must be handled by a professional technician according to the circuit diagram.
- 4) Set leakage protector according to the local code for wiring (leakage operating current $\leq 30\text{mA}$).
- 5) The layout of power cable and signal cable should be orderly and not affecting each other.

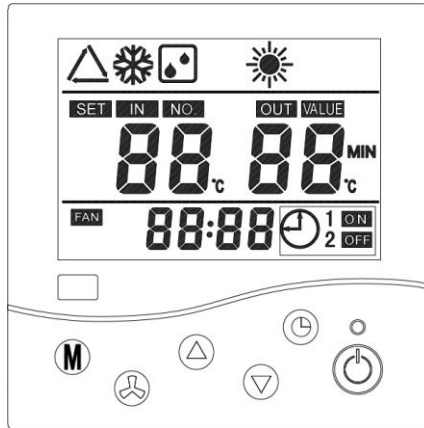

D. Switch on after finishing all wiring construction and re-checking.

VI. Operation instruction







Symbol	Designation	Operation
	Power ON/OFF	Press to power on or off the heat pump
	Up/ Down	Press to set desired water temperature
	Fan	Press to select Silence mode ON/OFF





Note:

- 1) You may set the desired water temperature from 18 to 35°C.
- 2) The  on the right shows the inlet water temperature. The  on the left shows the outlet water temperature.
- 3) After you turn on the heat pump, the fan will start to run in 3 minutes. In another 30 seconds, the compressor will start to run.











1. Status on the display

 Auto Mode  Defrost Mode  Heating Mode  Timer
ON/OFF

2. Time setting

- A. Press  for 5 seconds to enter time setting. 88:88 is flashing on the display
- B. Press  and  to adjust the time (fast adjusting by continuous pressing). Then, press  to confirm and exit.
- C. In the time setting mode, if no operation for 30 seconds, the previous pressing will be lost and exit automatically.

3. Timer on and off

- A. Press the  for 10 seconds to enter the timer setting. The “ON” will be flashing to enter the Timer ON setting. Press the  and  to adjust Timer ON time. You can choose Timer on (Display: ON), or Repeat Timer ON (display: 1 ON) by pressing . Then press  to confirm
- B. When the “ON” stops flashing, and “OFF” is flashing, you enter the Timer OFF mode. Press the  and  to adjust Timer OFF time. You can choose Timer OFF (Display: OFF), or Repeat Timer OFF (display: 2 OFF) by pressing . Then press  to confirm
- C. After entering the Time ON/OFF setting, press  directly without

adjusting the time to cancel the relevant Timer setting.

D. Exit automatically if no operation for 30 seconds in the Timer ON/OFF mode,



4. Silence mode

A. The Smart mode as default will be activated when the machine is tuned on. And the display shows “”

B. When machine is on, press “” button to enter the Silence mode.

 will be light. Press “” again to exit.

5. Compulsory defrost

A. When the machine is on heating and the compressor is working continuously for 10 minutes, press both “” and “” buttons for 5 seconds to start compulsory defrost. (Note: the break between compulsory defrost needs to be more than 30 minutes.)

B. The symbol of defrost is twinkling when machine is compulsory or auto defrost.

C. The period and ending of compulsory defrost is the same as auto defrost.

VII. Testing

1 . Inspection before use

- A. Check installation of the whole machine and the pipe connections according to the pipe connecting drawing;
- B. Check the electric wiring according to the electric wiring diagram and earthing connection;
- C. Make sure that the main machine power switch is off;
- D. Check the temperature setting;
- E. Check the air inlet and outlet.

2 . Trial

- A. The user must “Start the Pump before the Machine, and Turn off the Machine before the Pump”, or the machine will be damaged;
- B. The user should start the pump, check for any leakage of water; and then set suitable temperature in the thermostat, and then switch on power supply;
- C. In order to protect the swimming pool heater, the machine is equipped with a time lag starting function, when starting the machine, the blower will run 1 minutes earlier than the compressor;
- D. After the swimming pool heater starts up, check for any abnormal noise from the machine.

VIII. Precautions

1 . Attention

- A. Set proper temperature in order to get comfortable water temperature to avoid overheating or overcooling;
- B. Please don't stack substances that can block air flow near inlet or outlet area, or the efficiency of the heater will be reduced or even stopped;
- C. Please don't put hands into outlet of the swimming pool heater, and don't remove the screen of the fan at any time;
- D. If there are abnormal conditions such as noise, smell, smoke and electrical leakage, please switch off the machine immediately and contact the local dealer. Don't try to repair it yourself;
- E. Don't use or stock combustible gas or liquid such as thinners, paint and fuel to avoid fire;
- F. In order to optimize the heating effect, please install heat preservation insulation on pipes between swimming pool and the heater. During running period of the swimming pool heater, please use a recommended cover on the swimming pool;
- G. Connecting pipes of the swimming pool and the heater should be $\leq 10\text{m}$, or the heating effect of the heater cannot be ensured;
- H. This series of machines can achieve high efficiency under air temperature of $+15^{\circ}\text{C} \sim +25^{\circ}\text{C}$.

2 . Safety

- A. Please keep the main power supply switch far away from the children;
- B. When a power cut happens during running, and later the power is restored, the heater will start up automatically. So please switch off the power supply when there is a power cut, and reset temp when power is restored;
- C. Please switch off the main power supply in lightning and storm weather to prevent from machine damage that caused by lightning;
- D. If the machine is stopped for a long time, please cut off the power supply and drain water clear of the machine by opening the tap of inlet pipe.

IX. Maintenance

Caution: Danger of electric shock

“Cut off” power supply of the heater before cleaning, examination and repairing

- A. In winter season when you don't swim:
 - 1. Cut off power supply to prevent any machine damage
 - 2. Drain water clear of the machine.

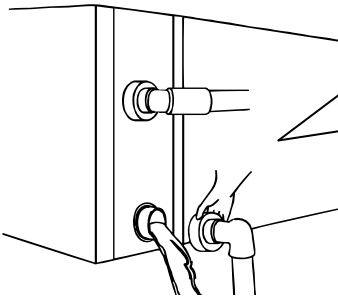

!!Important:

Unscrew the water nozzle of inlet pipe to let the water flow out.

When the water in machine freezes in winter season, the titanium heat exchanger may be damaged.

- 3. Cover the machine body when not in use.
- B. Please clean this machine with household detergents or clean water, NEVER use gasoline, thinners or any similar fuel.
- C. Check bolts, cables and connections regularly.

X. Trouble shooting for common faults

Failure	Reason	Solution
Heat pump doesn't run	No power	Wait until the power recovers
	Power switch is off	Switch on the power
	Fuse burned	Check and change the fuse
	The breaker is off	Check and turn on the breaker
Fan running but with insufficient heating	evaporator blocked	Remove the obstacles
	Air outlet blocked	Remove the obstacles
	3 minutes start delay	Wait patiently
Display normal, but no heating	Set temp. too low	Set proper heating temp.
	3 minutes start delay	Wait patiently
If above solutions don't work, please contact your installer with detailed information and your model number. Don't try to repair it yourself.		

Note: If the following conditions happen, please stop the machine immediately, and cut off the power supply immediately, then contact your dealer:

- a) Inaccurate switch action;
- b) The fuse is frequently broken or leakage circuit breaker jumped.

Failure code

NO.	Display	Failure description
1	E1	High pressure protection
2	E2	Low pressure protection
3	E3	No water protection (not failure)
4	E4	3 phase sequence protection (three phase only)
5	E5	Not failure, power supply exceeds operation range
6	E6	Excessive temp difference between inlet and outlet water(Insufficient water flow protection)
7	E7	Water outlet temp too high or too low protection
8	E8	High exhaust temp protection
9	EA	cooling coil pipe(heat exchanger)overheat protection
10	Eb	Ambient temperature too high or too low protection
11	Ed	Anti-freezing reminder (not failure)
12	P0	Controller communication failure
13	P1	Water inlet temp sensor failure
14	P2	Water outlet temp sensor failure
15	P3	Gas exhaust temp sensor failure
16	P4	Cooling coil pipe (heat exchanger) temp sensor failure at cooling mode
17	P5	Gas return temp sensor failure
18	P6	Heating coil pipe (evaporator) temp sensor failure
19	P7	Ambient temp sensor failure
20	P8	Cooling plate sensor failure
21	P9	Current sensor failure
22	PA	Restart memory failure
23	F1	Compressor drive module failure
24	F2	PFC module failure
25	F3	Compressor start failure
26	F4	Compressor running failure
27	F5	Inverter board over current protection
28	F6	Inverter board overheat protection
29	F7	Current protection

30	F8	Cooling plate overheat protection
31	F9	Fan motor failure

XI. Appendix: Heating priority (Optional)

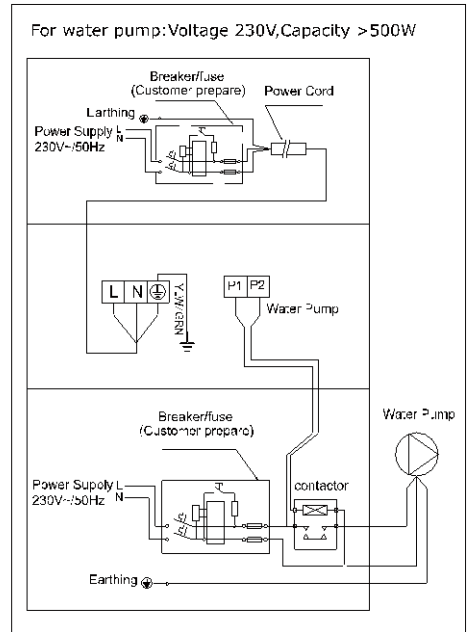
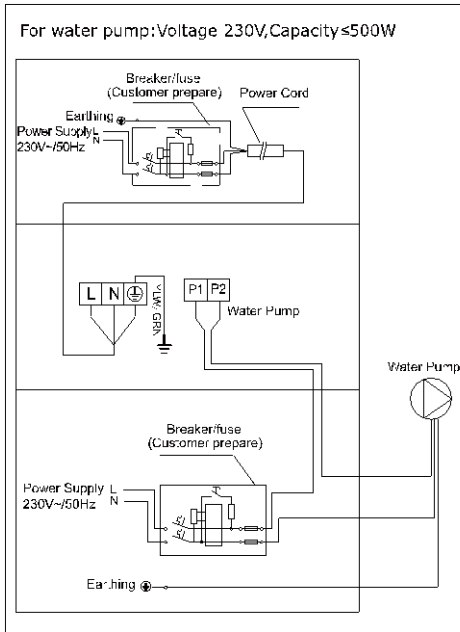

Parallel connection with filtration clock

A: Water pump timer

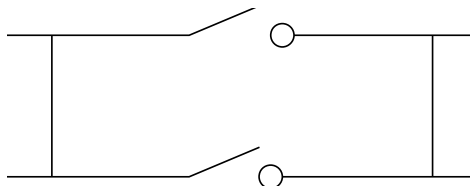

B: Water pump wiring of Heat Pump

Note: The installer should connect A parallel with B (as above picture). To start the water pump, condition A or B is connected. To stop the water pump, both A and B should be disconnected.