



Installation and Operation Manual



MODEL: PHPM1800 -75Kw

⚠ Warning

RISK OF ELECTRICAL SHOCK OR ELECTROCUTION. The electrical supply to this product must be installed by a licensed or certified electrician in accordance with applicable national and local codes and ordinances. Improper installation may cause electrical hazard, which could result in death or serious injury to pool or spa users, installers or others, and may also cause damage to property. Read and follow the specific instructions inside this manual.

Manual Revision Date 150413

Contents

I 、 Operating Principle and description	3
II 、 Main characteristics	4
III、 Technical data.....	5
IV、 Electrical circuit diagram	5
V 、 Operating instructions	7
VI、 Instructions for installation	14
VII、 Safety Warnings and Cautions	19
VIII、 Trouble shooting and solutions	20

I 、 Operating principle and description

1、 Description

A swimming pool heat pump comprises a compressor, an evaporator, some capillary or expanding valves and a condenser.

2、 Operating principle

A heat pump use electricity to capture heat and move it from one place to another. It doesn't generate heat. As the pool water pump circulates the swimming pool's water, the water drawn from the pool passes through a filter and the heat pump heater. The heat pump heater has a fan that draws in the outside air and directs it over the evaporator coil. Liquid refrigerant within the evaporator coil absorbs the heat from the outside air, which causes the refrigerant to become a gas. The warm gas in the coil then passes through the compressor. The compressor increases the heat, creating a very hot gas which then passes through the condenser. The condenser transfers the heat from the hot gas to the cooler pool water which is circulating through the heater. The heated water then returns to the pool. The hot gas, as it flows through the condenser coil, returns to liquid form and then travels back to the evaporator, where the whole process begins again.

3、 Example of how a heat pump operates.

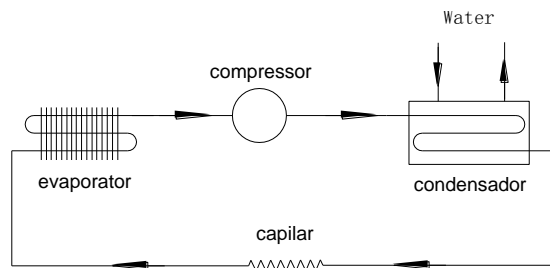

photo1: ventilation defrosting type

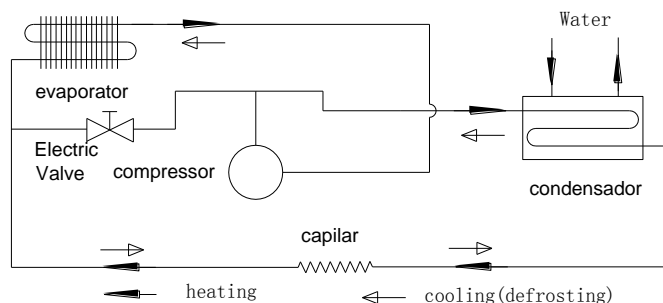

photo2: system defrosting type

II、Features

1、Efficient and economical

The unit's Coefficient of Performance (cop) \geq 4.0. In comparison, an electric boiler (cop) \leq 0.95, a gas or oil boiler (cop) is about 0.5--0.8, a coal-boiler (cop) is only about 0.3--0.7. High efficiency means low operating costs.

2、Safety ensured

When the unit is operating, all electrical components are completely isolated from circulating water. Potential dangers such as explosion, dry heating, gas poisoning, which may be possible with petroleum gas or diesel pool heaters, are not an issue with an electrical heat pump.

3、Environmentally friendly

The applied refrigerant is not Freon, and when the unit is operating, no waste water, no waste residue, no waste heat, no waste gas or other pollutant will be generated or emitted.

4、Installation convenience

Your Heat Pump can be easily installed in an outdoor area, balcony, flat roof, equipment room, or other flat stable surface. A special room or enclosure is not required.

5、Modularized control function

You can combine several units to make one hot water supply system of increased heating capacity, controlled by a single controller (modularization). The system can adjust the run time and order automatically. The entire system can run efficiently, and every unit's status can be controlled and interrogated through the single controller.

6、Operational convenience

This unit is controlled by microcomputer. The unit will receive sensor and controller inputs, water temperature and water circulation inputs. The unit will then self-adjust to provide efficient heating without operator input.

7、Automatic defrost function

With the intelligent defrost function, you can set defrost condition parameters according to different climates enabling the unit to defrost in a flexible way.

8、Far-ranging applicability

There are a vast range of applications. This unit can be used in hotels, aquatic centers, Commercial hot water supply, indoor pool facilities, in-fact anywhere a hot water supply is required.

III、 Technical Data

Data Model	Main Technical Data							
	Heating Capacit y (Btu)	Rated Power (W)	Stated Currency (A)	Power Input (V/PH/Hz)	Noise Level [dB (A)]	Water Flow (m ³ /h)	In\Out Pipe Size (mm)	Dimension (mm)
PHPM1800	255900	15500	28.5	380/3/50	65	≥20	75	1530*830*1800

IV、 Circuit diagram

1) Circuit diagram

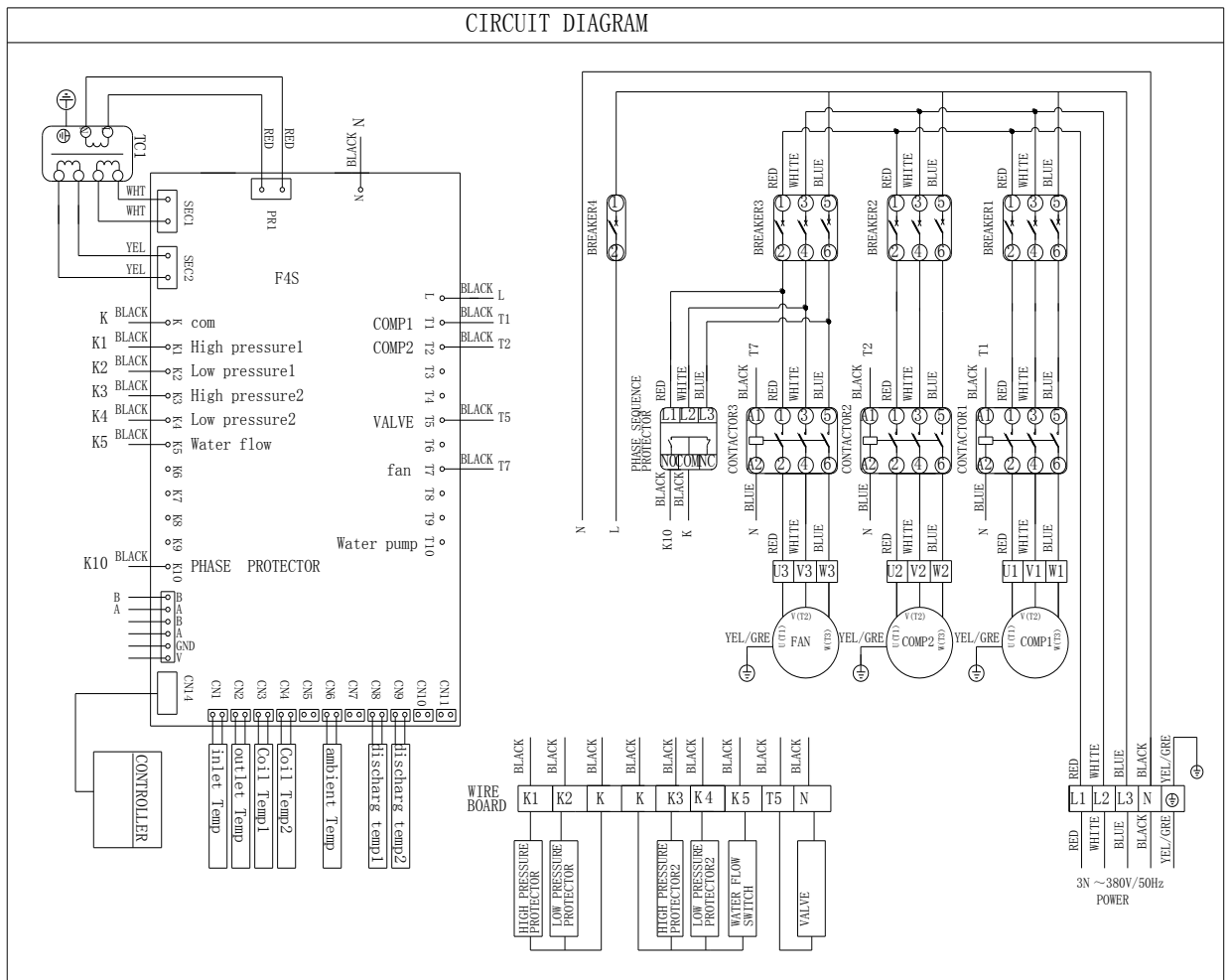

2) Modular connection setting diagram

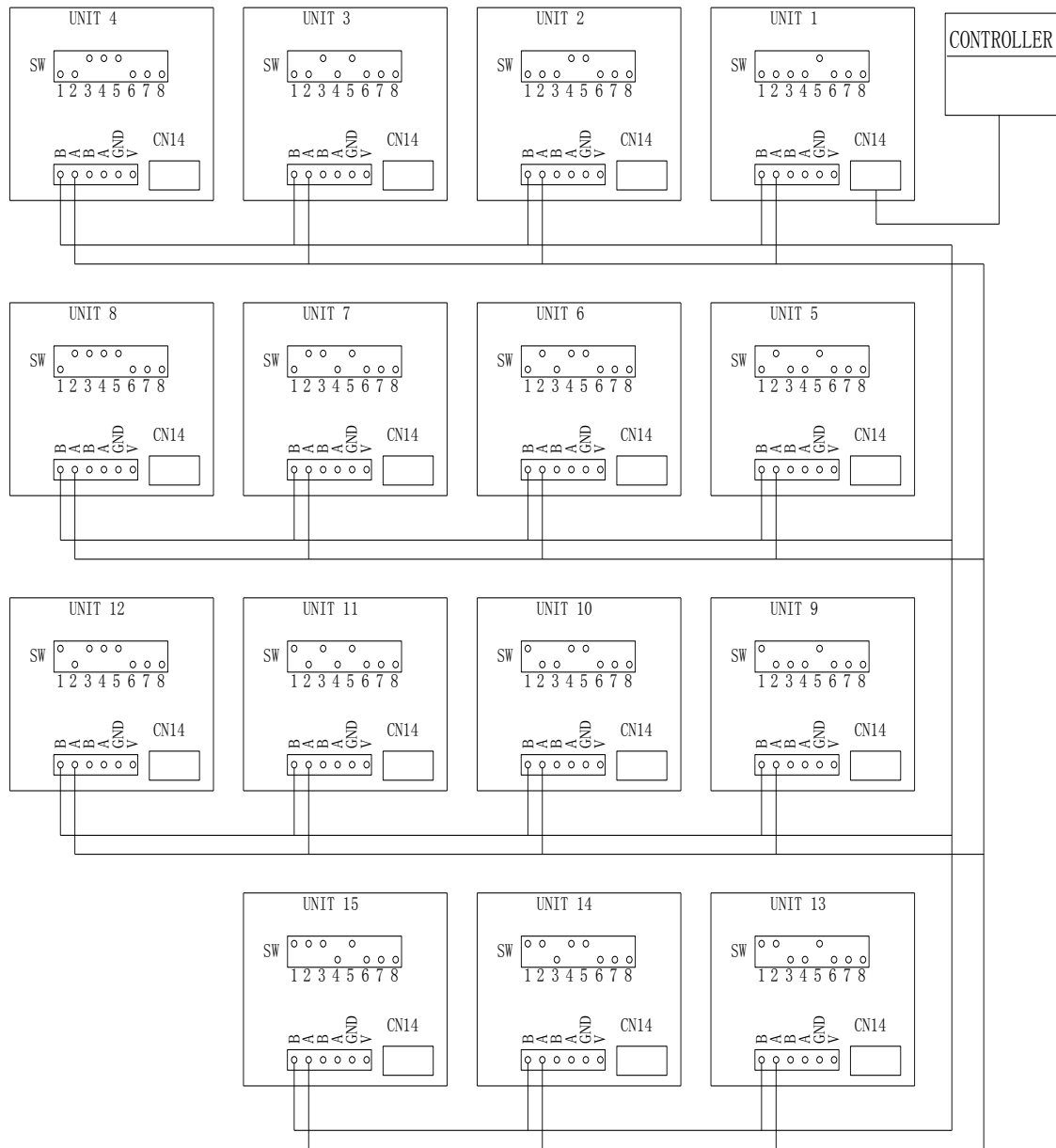

- SW1~4: Address setting switch, setting method as shown on the above drawing
- SW5: MUST be "ON", refer to the above drawing
- SW6: MUST be "Off", refer to the above drawing
- SW7~8: MUST be "OFF", refer to the drawing
- Before delivery, SW5~8 has been pre-set. During commissioning, technician needs to adjust SW1~4 according to the module quantity.
- Maximum number of units is 15.



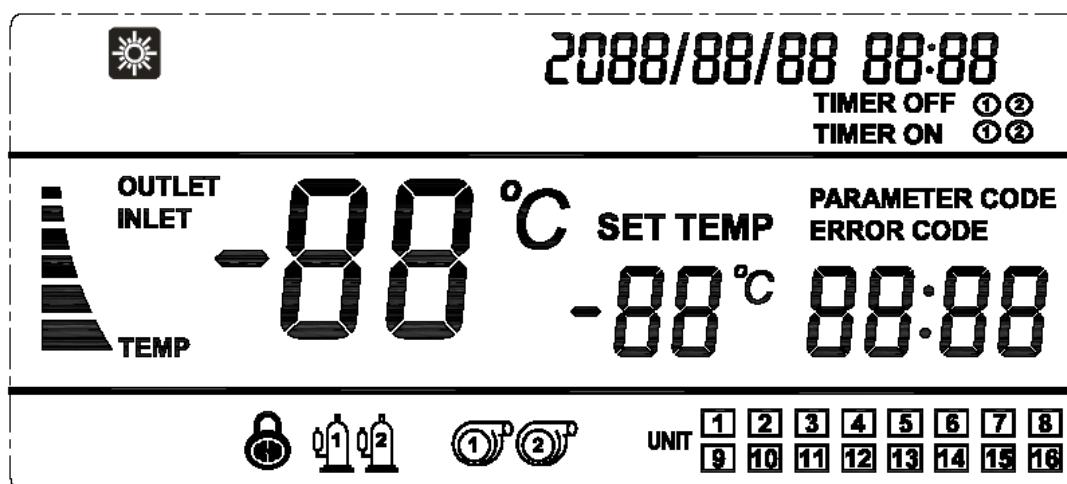

V、Operational instructions

1. The basic functional description is detailed below

- total of eight function areas
- the MAX485 communications
- the precise real-time clock
- the two section timer
- all unit data – status and interrogation
- parameters settings
- all units error code diagnosis and display
- the in-line unit indication
- the LCD sketch



● Icon Meanings

	Heating Mode		Compressor
	the locking status		Water pump
UNIT 	Module number		

- the controller key pad layout



2. the key pad description

- 2.1. : ON/OFF, to run or to stop the unit group.
- 2.2. **M**: MODE, to select the operating mode function, and to enter into one unit parameter group setting by a long press when querying data.
- 2.3. : ENTER
- 2.4. : INCREASING, to increase temperature value ,parameter value, or to select the next item number up when querying data.
- 2.5. : DECREASING, to decrease temperature value ,parameter value, or to select the next item number down when querying data.
- 2.6. : to select the item number sequentially when setting the parameter.
- 2.7. : CLOCK, to set the clock and the timer.
- 2.8. : TIME INCREASING, to increase the current clock value or the timer setting value.
- 2.9. : TIME DECREASING, to decrease the current clock value or the timer setting value;

2.10. **IP**: IP, to enter into the data interrogation modes and select one unit in line to display this data.



2.11. **P** : PROGRAM, to select the multi timing section when setting the timer.

2.12. : LOCK.





2.13. **Zz**: CANCEL, by pressing this key, the operator can exit from all special procedures, including the parameter settings, timer settings, and data querying.

3. Customer operation and display









3. 1. ON/OFF switching:



- When the unit/s are in “OFF” status, to start up the unit group press the  key;
- When the unit/s are in “ON” status, to shut down the unit group press the  key;

3. 2. The temperature setting:

- When the unit is in “normal” mode and “ON” status, to increase or decrease the commanded temperature value press the  or  key;
- The setting range: Heating mode (10~40) °C;
- Default value: Heating mode 28°C;
- After pressing and holding the  or  key, to increase or decrease the display will change the setting temperature rapidly;



3. 3. Current time setting:

- After pressing  key in “normal” mode, the two digits of years will blink (once per second), and the years adjustment can be achieved by pressing  or  key;
- Pressing  key once more, the two digits of months will be flash (once per second), and the months adjustment can be achieved by pressing  or  key;
 - By pressing  key repeatedly, the different “time fields” can be selected and continually adjusted as the following sequence shows: years→months→date→hours→minutes;
- After pressing  key, the current “time field” value as set by the operator will be ”stored” and the display will move into the next “time field” automatically;
- The time setting process will be exited automatically if no entry or action is made via the key pad.



- After pressing and holding the  or  key, for 1.5 seconds it will cause the display to increase or decrease rapidly (one time unit at 0.3 second interval);
- Every time setting range:
years: 00~99;
months: 1~12;
date: 1~31;
hours: 0~23;
minutes: 0~59;

The controller Keypad panel can be locked to avoid inadvertent setting changes:



3. 4. Locking

- In normal mode this symbol indicates that the unit/s keypad is locked “” and “LOCK” will appear in the error code display as a result of pressing the  key for more than one second.
- In “lock mode”, any action on the keypad will not be accepted, and will result in the symbol LOCK being displayed again for about 5 seconds.
- The status will be recorded in flash memory.

3. 5. Unlocking

- After pressing the key above for one second whilst in the locked mode, the controller will exit from the “locked” status and the symbol  will disappear and the symbol “LOCK” will also disappear from the display after releasing the  key (after 5 seconds);
- All the key functionality will resume to normal after unlocking;
- The status will be recorded in flash memory.

3. 6. Operational data interrogation for the unit/s:

- Such action is available whether the unit/s are in ON/OFF status.
- To enter into data interrogation – press the IP key.
- During the data interrogation, the controller will display the ID number of the associated unit in the unit group area, the data sequence number or symbol on temperature setting area, and the data value or status on the current temperature area.
- To select different units in line - re press the IP key.
- To display the different data in sequence - press the  or  key as detailed: AD1→AD2→AD3→AD4→AD5→AD6→AD7→AD8→AD9→AD10→AD11→DI→DO;

- During the data interrogation, the unit status area











will display the current unit status of components such as compressor and pump.

- During the data interrogation, the controller will return to the normal mode if no action or keypad entry is made within 10 seconds.
- Data comparison table:

No.	content
01	Unit inlet temperature
02	Unit outlet temperature
03	Coil 1 temperature
04	Coil 2 temperature
05	Coil 3 temperature
06	Unit ambient temperature
07	Coil 4 temperature
08	Unit exhaust 1 temperature
09	Unit exhaust 2 temperature
10	Unit exhaust 3 temperature
11	Unit exhaust 4 temperature
DI	N/A
DO	N/A

3. 7. Setting the timer

- Whilst in the ON/OFF mode, the operator can enter into the timer mode section for timer setting.
- After pressing the **P** key, the timer display will show the “ON time”, ②, and the “OFF time”, ①②, the blinking of digit ① following timing ON indicates – operator is to set the first timing segment of timing on. At same time ,the “time display” will show the setting time(for either the “ON” or “OFF” time)
- By pressing the  or  key repeatedly, the operator can shift between displaying, in turn either the “ON” or “OFF” time.
- To confirm the current settings - press the  key.
- The operator can enter into the next “timing segment” to adjust of “ON time” or “OFF time”, or by pressing the **P** key again while releasing current settings, or by pressing  key while confirming current settings.

- By pressing the P key repeatedly, the operator can shift in turn as following: timing ON 1--- timing OFF 1---- timing ON 2--- timing OFF 2-- timing ON 3--- timing OFF 3. (Where 1,2,3 denotes the timer “ON- OFF” period number)
- After the adjustment of the timer periods, if one timing segment adjustment is being displayed (showing time), then the hour adjustment can be made (when the “hours field” is blinking) by pressing the  key, the minutes adjustment when the “minutes field” is blinking, by pressing the  key again.
- To adjust the time value – press the  or  key.
- By pressing  key, to confirm the current settings and return to the validity adjustment.
- The controller will exit from the timer settings mode if no any action or keypad inputs are made within 10 seconds.
- Pressing P key for 5 seconds will cancel all the timer settings.

3.8. Error codes

3.8.1 If the system registers a fault, then the control panel will display all error codes will be displayed sequentially.

3.8.2 All unit error codes will be displayed in sequence at 2 second intervals - repeatedly.

3.8.3 The error code format – The first digit and second digit is the number of the unit at fault,, the third and fourth digit is error code, for example : the error code 05 of unit 1 is displayed as following

ERROR CODE
5 1:05

3.8.4 Error code list

Error code	content	treatment
Temperature Sensor Error codes		
En: 01	inlet sensor short or open circuit	Shutdown all unit in line, auto-recovery
En: 02	outlet sensor short or open circuit	Shutdown all unit in line,, auto-recovery
En: 03	Coil 1 sensor short or open circuit	Shutdown all unit in line,, auto-recovery
En: 04	Coil 2 sensor short or open circuit	Shutdown all unit in line,, auto-recovery
En: 05	Coil 3 sensor short or open circuit	Shutdown all unit in line,, auto-recovery
En: 06	ambient sensor short or open circuit	Shutdown relevant unit, auto-recovery

En: 07	Coil 4 sensor short or open circuit	Shutdown all unit in line,, auto-recovery
En: 08	Discharge1 sensor short or open circuit	Shutdown relevant units, auto-recovery
En: 09	Discharge2 sensor short or open circuit	Shutdown relevant units, auto-recovery
En: 10	Discharge3 sensor short or open circuit	Shutdown relevant units, auto-recovery
En: 11	Discharge4 sensor short or open circuit	Shutdown relevant units, auto-recovery
Note: "n" denotes unit number		
Refrigerant Error codes - open contact types		
5n: 01	High pressure1	Shutdown relevant unit, recovering after power on again or press reset.
5n: 02	Low pressure1	Shutdown relevant unit, recovering after power on again or press reset.
5n: 03	High pressure2	Shutdown relevant unit, recovering after power on again or press reset.
5n: 04	Low pressure 2	Shutdown relevant unit, recovering after power on again or press reset.
5n: 05	Water flow switch	Shutdown all unit in line, recovering after power on again or press reset.
5n: 06	High pressure3	Shutdown relevant unit, recovering after power on again or press reset.
5n: 07	Low pressure3	Shutdown relevant unit, recovering after power on again or press reset.
5n: 09	High pressure4	Shutdown relevant unit, recovering after power on again or press reset.
5n: 10	Three-phase power protection	Shutdown all unit in line, recovering after power on again or press reset.
5n: 14	Low pressure 4	Shutdown relevant unit, recovering after power on again or press reset.
Additional Error code types		
Hn: 01	Low water outlet temp protection (not applicable for heating only units)	Shutdown relevant units, auto-recovery
Hn: 02	high water outlet temp protection (not applicable for cooling only units)	Shutdown relevant units, auto-recovery
Hn: 05	High temp. difference protection between inlet and outlet	Shutdown all in line units, recovering after power on again or press reset.
Hn: 07	Discharge1 protection	Shutdown relevant units, auto-recovery
Hn: 08	Discharge2 protection	Shutdown relevant units, auto-recovery
Hn: 11	Discharge3 protection	Shutdown relevant units, auto-recovery
Hn: 11	Discharge4 protection	Shutdown relevant units, auto-recovery
EE: 40	Communications failures	Shutdown relevant units, auto-recovery

VI、 Instructions and notices for installation

1、 Materials Needed For Installation:

- 1、 Plumbing connections ($\phi 32\text{mm}$ or $\phi 50\text{mm}$ or $\phi 62\text{mm}$) ;
- 2、 Level surface with proper drainage;
- 3、 Suitable electrical supply line. See rating plate on unit for electrical specifications. A junction box is not needed at the heat pump; Electrical connections are made inside the heat pump electrical compartment. Conduit may be attached directly to the heat pump case.
- 4、 Electric Isolation switch. This switch must be in close proximity to the heat pump and, as specified by local power authority regulations
- 5、 Watertight conduit in which to enclose the electrical supply line.
- 6、 It is recommended that isolation valves be installed on the inlet and outlet water connections for ease of serviceability.

NOTE: Flexible conduit is recommended for connecting the electrical supply wiring to the heat pump so that the front panel can be removed easily, if necessary for servicing.

2、 The requirements for heat pumps include the following

- 1、 Appropriate site location and clearances;
- 2、 Sufficient air ventilation and unrestricted airflow;
- 3、 Proper electrical wiring carried out by an authorized electrical technician;
- 4、 Adequate water flow;

NOTE: This manual provides information needed to meet the above requirements. Review all applicable sections and installation procedures completely before continuing the installation。

3、 Clearances

Avoid placing the heat pump in locations where it can cause damage by water or condensate discharge. If this is not possible, provide a suitable drain pan to catch and divert any condensate. All criteria given in the following sections reflect minimum clearances. However, each installation must also be evaluated, taking into account the prevailing local conditions such as proximity and height of walls, and proximity to public access areas.

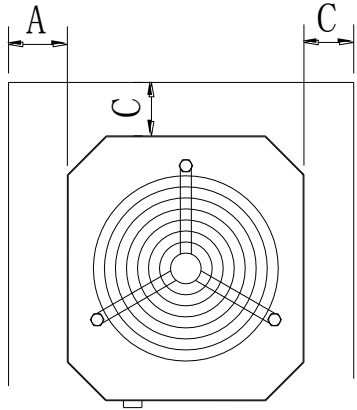

	Minimum Clearances for Operation	Recommended Clearances for Serviceability
A	15cm	60cm
B	15cm	30cm
C	15cm	30cm
Top	150cm	150cm

4、 Equipment Pad

Place the heat pump on a flat slightly pitched surface, such as a concrete or fabricated slab (pad). This allows proper drainage of condensation and rain water from the base of the unit. If possible, the pad should be placed at the same level or slightly higher than the filter system equipment pad.

5、 Indoor Installations

See Figure 1 (Standard plumbing Layout, Indoor)

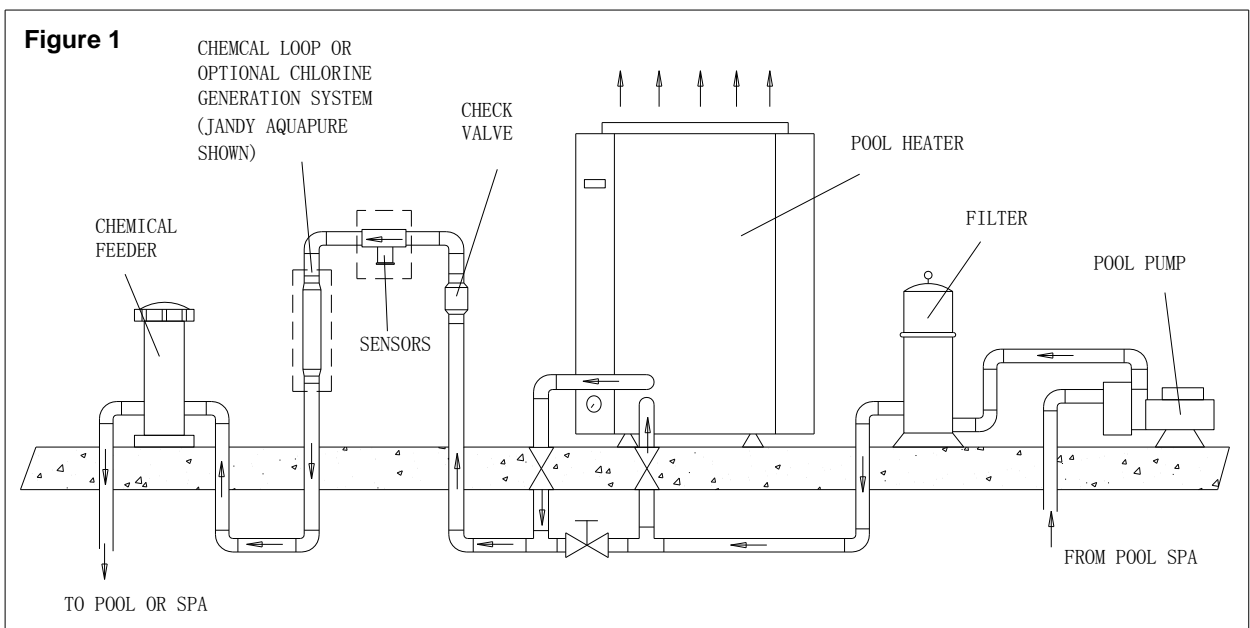

5.1、 Condensation and Drainage

Condensation from the evaporator coil will occur while the unit is running, depending upon ambient air temperature and humidity. The higher the ambient humidity conditions, the more condensation will be produced. For indoor installations, a means of condensate disposal must be provided. The drain hole in the base of the heat pump is fitted with a 19mm diameter barbed adapter and tubing should be used to route condensate into a drain or to the outside of the building, where necessary.

NOTE: It is important to remember that no part of the tubing or hose may be above the level of the drain hole in the base of the heat pump.

5.2、 Check Valve Installation

The inlet/outlet header of the heat pump should be fitted with a water flow control valve. The water flow control valve should maintain the proper water flow rate through the heat pump.

NOTE: Excess water flow will damage the heat exchanger.

6、 Filtration System Layouts

6.1、 Shared Filtration System

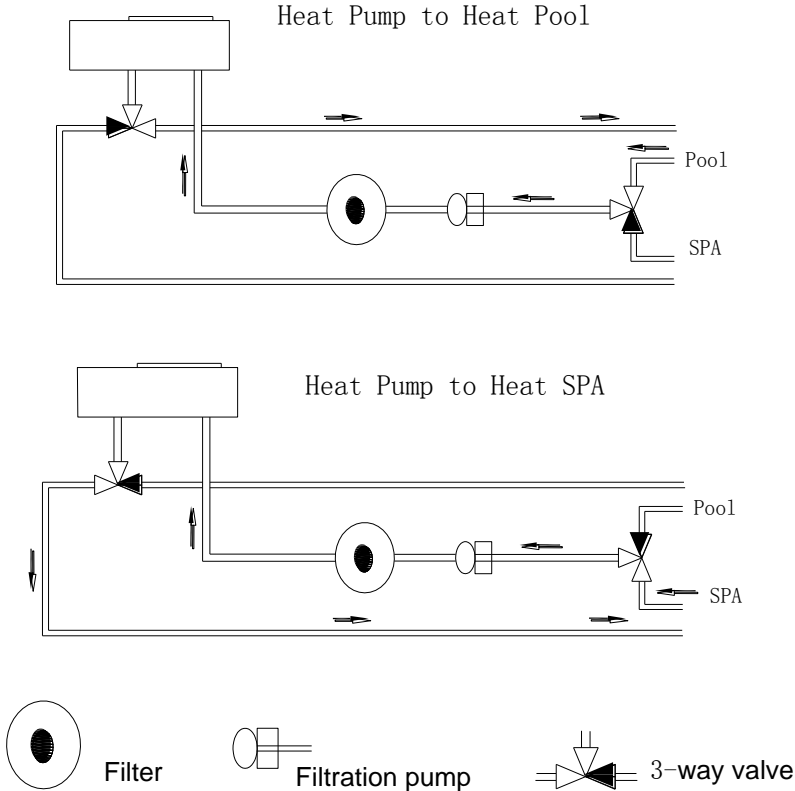

6.2. Independent Filtration System

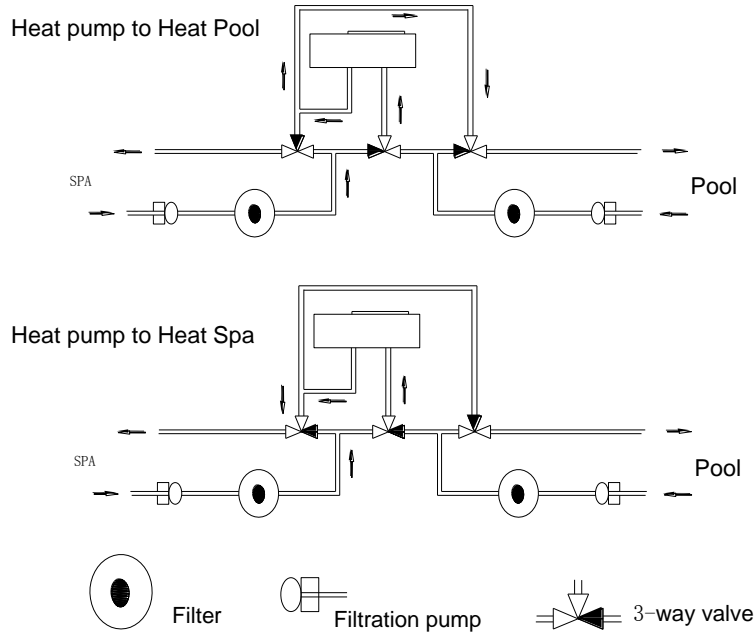

7. Multiple Heat Pump Connections

All plumbing on multiple heat installations **MUST** be done in parallel (see figures 2 and figures 3). An equal flow of water to each heat pump is important for optimum operation.

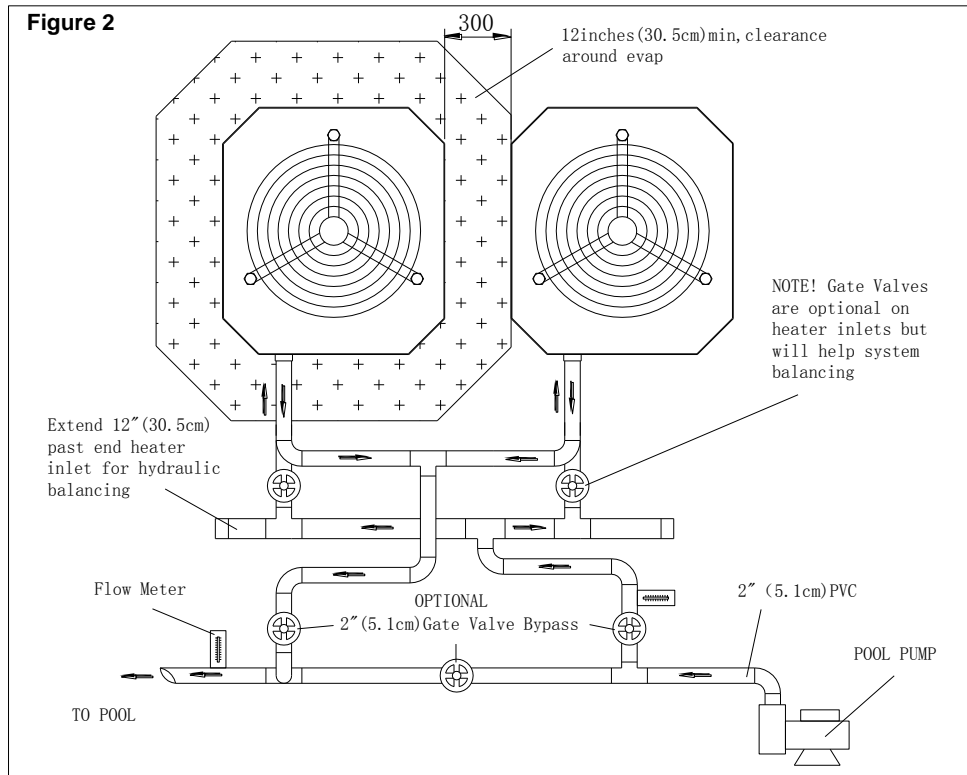

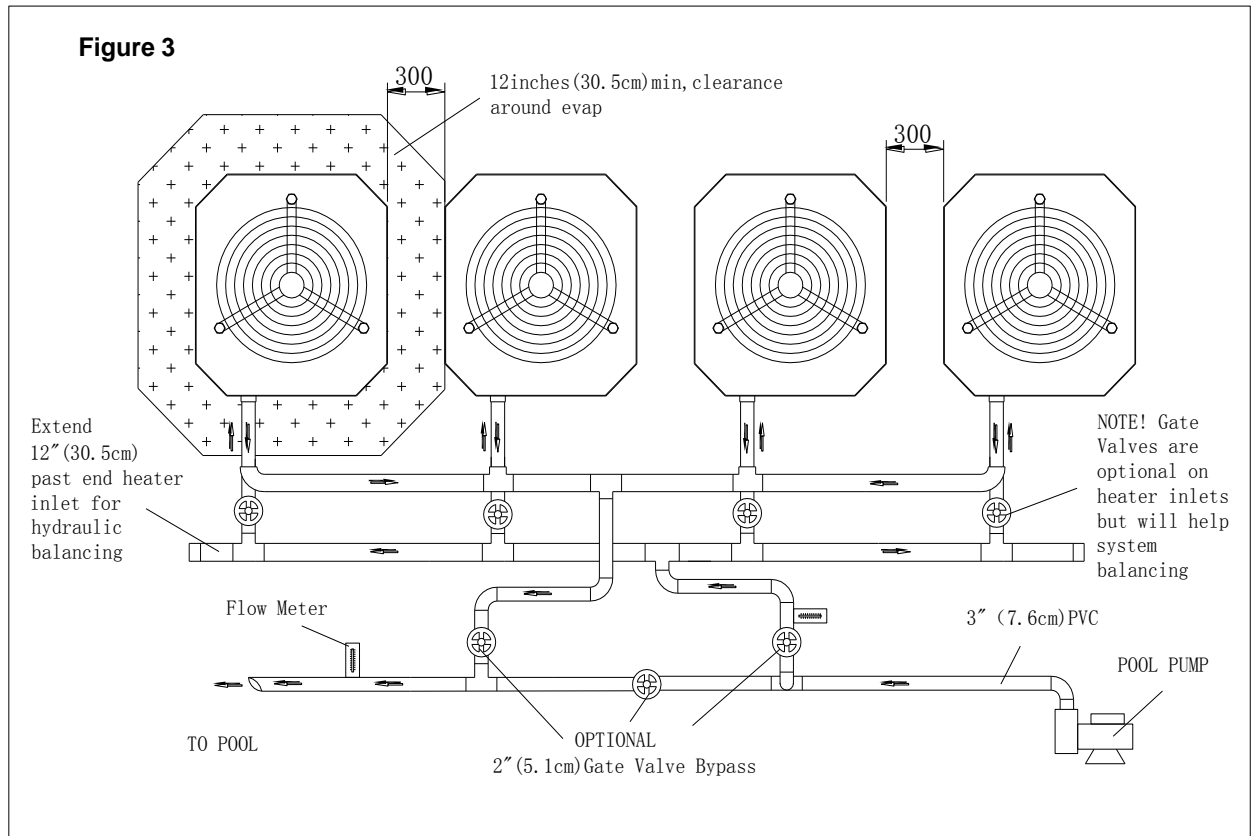

8. Instructions for installation

- ⚠ The proposed unit location must be sturdy and able to withstand its weight. If not, it is possible that the unit may fall and be badly damaged or destroyed.
- ⚠ The electrical system must comply with the local regulations and the installation must be in accordance with the rating data in the technical sheet.
- ⚠ If the unit is installed in an area with inadequate or restricted airflow, the unit will not operate effectively and could be damaged.
- ⚠ Low voltage or incorrect power connection will cause damage to the unit or injury.
- ⚠ The unit must be effectively earthed and proper connection to the mains power supply using appropriate cable capacity / size is required.
Failure to comply may result in fire or electric shock.
- ⚠ After the pool water pipe connection and system has been installed, ensure that the system is thoroughly cleaned and flushed before connection to the Heat pump unit.
- ⚠ The water pipe systems must be tested for compression resistance in order to check whether there is any water leakage.
- ⚠ There must be adequate room around the unit for air flow and any maintenance operations that may be necessary.

VII、 Safety Cautions

Attention:

- Water flow through the unit must always be adequate. The pool water level must always be above the minimum .
- Do not stop and restart the unit repeatedly; A 5 minute “wait time” between restart attempts is required.
- If the pool water pump fails, turn the unit OFF immediately.
- Please cover and protect the unit from dirt and debris, if it is to remain out of operation for an extended period.
- Please ensure that the evaporator is regularly cleaned by a qualified technician .If the unit has been operating for an extended period a build up of foreign material may have formed on the Evaporator coil causing the airflow volume to decrease.
- To increase efficiency, don't set the temperature too high or too low.
- Do not install or operate the unit near heat sources, fires or in the vicinity of flammable liquids or in areas of high atmospheric pollutants (eg smoke, soot or dust).
- Do not insert fingers or other body parts or any other foreign object into any part of the unit including the fan. SERIOUS injury will result
- Do not repair the unit yourself. Only suitably qualified personnel should service or repair the unit. Please contact a service technician in the event that the unit displays error an error code.
- Do not spray flammable chemicals around or into the unit

VIII、 Troubleshooting and solutions

SYMPTOM	CORRECTIVE ACTION
Heat pump does not start, no display on the control panel	Breaker or fuse may be tripped. Reset breaker or check fuse. If heat pump still does not run, call for service. Three-phase models only - the phases may be reversed or there may be a loss of phase, call for service.
Heat pump does not start, control board display working	Heat pump may be in delay count down of 3 minutes. Make sure control board thermostat is commanding for heater to come on (check setting on thermostat and temperature reading). Make sure heat pump is not in cooling mode.
Heat pump runs but does not heat	Verify cold air is blowing out the top of the heat pump. If the heat pump has just been installed or if the pool water has been allowed to cool significantly, it is necessary to run the heat pump continually, for 24-48 hours. Initial heat rise can be slow. If the heat pump has been in operation for some time, increase the circulating pump time, or switch the control board to Maintain Heat function. If heating a spa, verify no air intake stand pipes are open. If heat pump still does not heat, call for service.
Heat pump leaking water	Possible heat exchanger or plumbing leak. Turn the heat pump off, then turn circulating pump off for at least one hour to see if the water leak stops. If the water leak stops. Normal condensation is occurring. If the water leak continues, after the heat pump is shut off for at least one hour, call for service.



PREMIER HEAT PUMPS Ltd - AUCKLAND NEW ZEALAND