



Installation and Operation Manual



MODEL: PHPM300 – PHPM800 series



Congratulations on the purchase of your Premier Heat Pumps swimming pool / Spa pool hot water heat pump.

Our Heat Pumps are manufactured to the highest standards and quality, designed for New Zealand conditions. Our heat pumps incorporate high quality compressors, stainless steel cases, Digital controllers and Titanium heat exchangers.

It is important to read this instruction manual prior to installation and that it is retained for future reference.

Warning

RISK OF ELECTRICAL SHOCK OR ELECTROCUTION. The electrical supply to this product must be installed by a licensed or certified electrician in accordance with applicable national and local codes and ordinances. Improper installation may cause electrical hazard, which could result in death or serious injury to pool or spa users, installers or others, and may also cause damage to property. Read and follow the specific instructions inside this manual.

Contents

1~Operating Principle and technical description	2
2~Features and characteristics	3
3~Technical data	4
4~Electric circuit diagram	5
5~Operational instructions	6
6~Instructions and notices for installation	13
7~Safety Cautions	20
8~Troubleshooting and solutions	21

1. 1, Technical Description

The swimming pool heat pump water heater basically comprises a compressor, an evaporator, capillary or expanding valves and a condenser.

1.2, Working principle

Heat pumps use electricity to capture heat and move it from one place to another. They don't generate heat. As the pool pump circulates the swimming pool's water, the water drawn from the pool passes through the pool filter and the heat pump heater. The heat pump heater has a fan that draws in the outside air and directs it over the evaporator coil. The liquid refrigerant within the evaporator coil absorbs the heat from the ambient air and becomes a gas. The warm gas in the coil then passes through the compressor. The compressor increases the heat, creating a very hot gas that then passes through the condenser. The condenser transfers the heat from the hot gas to the cooler pool water circulating through the heater. The heated water then returns to the pool. The hot gas, as it flows through the condenser coil, returns to liquid form and travels back to the evaporator, where the whole process begins again.

1.3 Example of how a heat pump operates.

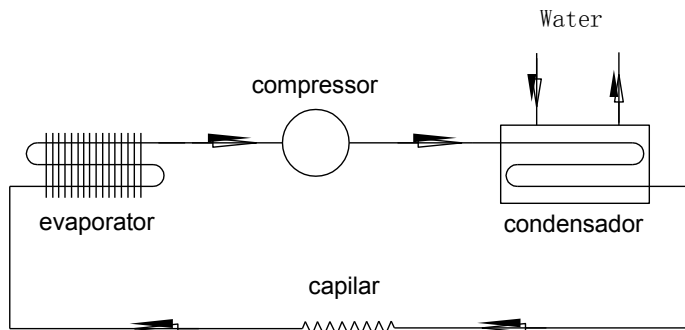

photo1: ventilation defrosting type

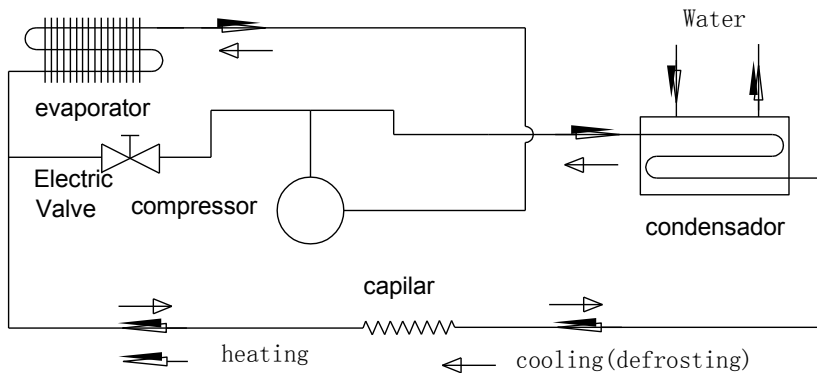

photo2: system defrosting type

2. Features and Characteristics

2.1, Efficient and economical

This unit's Coefficient of Performance (cop) is 4.0 -5.0. In comparison, an electric boilers (cop) is 0.95, a gas or oil boiler (cop) is about 0.5 - 0.8, a coal-boiler (cop) is only about 0.3-0.7. This means high efficiency, energy performance and savings.

2.2, Safety

When the unit is operating, all electrical parts are absolutely isolated from circulating water, thus avoiding any possible dangers. There is no chance of gas poisoning or fire, which can occur with a common diesel or gas water heater.

2.3, environmentally friendly

The applied refrigerant is not Freon, the refrigerant is either environmentally friendly R410a or R407C and when the unit is working, no waste water, no waste residue, no waste heat and no waste gas will pollute the environment.

2.4, Installation – convenient and simple

The heat pump can be installed outdoors, on a balcony, flat roof or equipment room, and does not need a purpose built room for installation. The unit must be installed in a well-ventilated or outdoor location.

2.5, modularized control function

Several units can be combined to make one larger hot water supply system controlled by modularization. The system can adjust the running time and order automatically, allowing the whole system to run efficiently, and every unit's total running time can be unified.

2.6, Operation is simple and convenient

The unit is controlled by microcomputer. According to the condition of water temperature and circular water volume, the unit will self-adjust and there is no need for constant attention.

2.7, Automatic defrost function

With intelligent defrost function, you can set defrost condition according to different climates to make the unit defrost in a flexible manner.

2.8, Versatility of application.

These units can be used to heat swimming pool or spa pool water, for schools, domestic or commercial installations, or wherever hot water is required.

3, Technical Data

Data Model	Main Technical Data							
	Heating Capacity (Btu) (aprox)	Rated Power (W)	Stated Current (A)	Power Input (V/PH/Hz)	Noise Level [dB (A)]	Water Flow (m ³ /h)	In\Out Pipe Size (mm)	Dimension (mm)
PHPM600	49400 14.70 kw	2770	11.7	240/1/50	47	≥6.5	50	575*575*750
PHPM700	64000 19.00 kw	3600	17.0	240/1/50		≥9.0	50	625*625*905

4. Electrical circuit diagram

4.1, Ventilation and defrosting

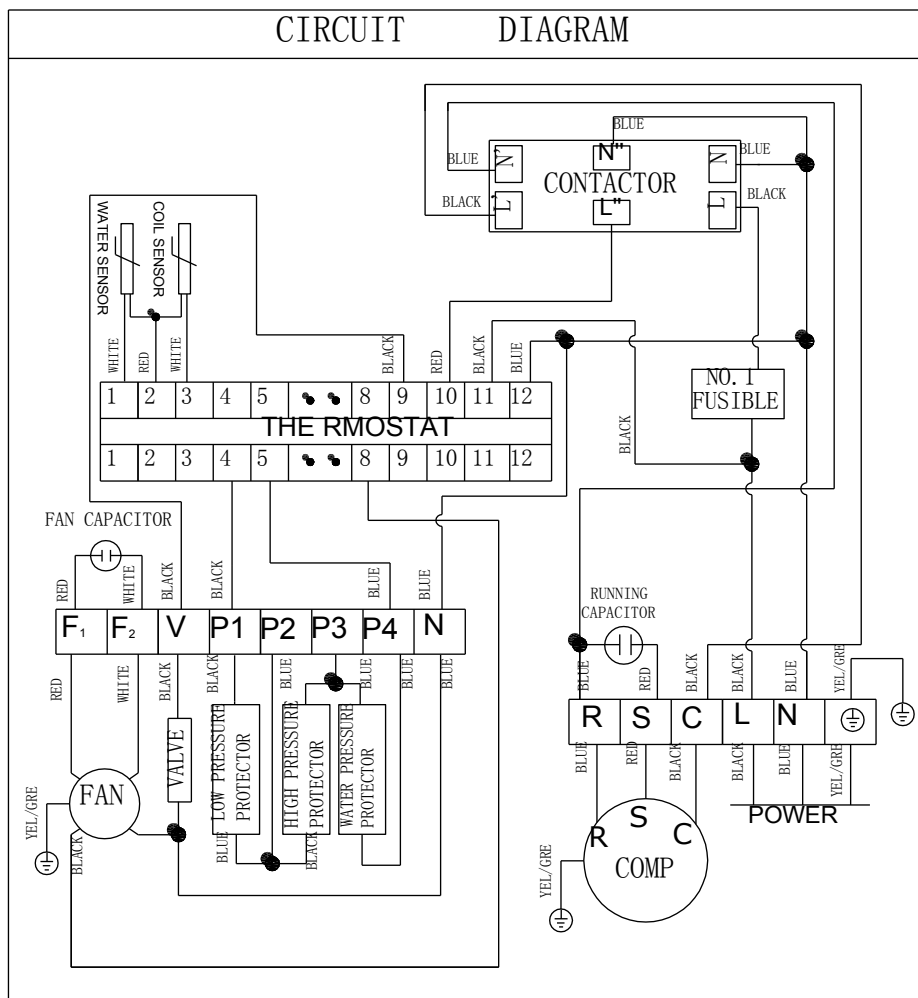







5. OPERATIONAL INSTRUCTIONS

5.1 Panel:



Panel and Functional description.

Index Light	Name	Light	Flash
	Temp Setting	In the state of temp setting	-
	Refrigeration	Refrigerating	Ready to refrigerate, in the state of compressor start delay protection
	Heat	Heating	Ready to heat, in the state of compressor start delay protection
	Defrost	Defrosting	Ready to defrost, in the state of compressor start delay protection
	Fan	Fan operating	-
	Alarm	-	Alarm state

5.2 The controller LED display

The LED Panel shows the pool temperature, if the display shows “SHr” or “OPE” then there is a water temperature sensor failure. The temperature and the alarm code (Axx) will show alternately when there is an alarm state.

The fault codes are shown below:

Code	Signification	Explanation
A11	External alarm	Alarm from external alarm signal, please refer to the internal parameter code “F50”. This alarm signal is triggered when the water pressure is lower than operating level at 0.1kg/cm ² and/or refrigerant pressure is out of the range 0.15MPa - 4.1MPa.
A21	Water temperature sensor error	Open or short (showing “OPE” or “SHr”)
A22	Outdoor machine sensor error	Open or short (showing “OPE” or “SHr” when press the key “  ”)
A99	Over probation time	If you have set the probation time F87, the alarm occurs when the accumulative running time is over probation time, In this case the controller will cease to operate.

5.3 How to set the heat pump temperature

Press the key “set” for at least 2 seconds, to enter the “required temperature setting” mode, the LED displays the required temperature, then using “↑” key or “↓” key to either increase or decrease the parameter (the key“↑”adds 0.1°C, the key“↓”minuses 0.1°C, press and hold the key for more than 0.5 seconds for rapid adjustment) . After setting is complete, press “set” again, to exit the temperature setting mode. (The setting temp range is limited by the parameters F13 and F14, please refer to the advanced operation). Pressing the key “M” in the setting process means cancel and exit, but the setting value will not be saved.

5.4 How to read the outdoor temperature

When displaying current temperature, press “↓” key, Controller will display defrosting temperature. Release the “↓” key, then return to current temperature. Notice that if you press the key and hold it for 5 seconds, the controller will enter or exit the defrosting state forcibly.

5.5 How to check and adjust the real clock time

Press the key “Set” to enter the mode “displaying time” when in the mode of displaying temperature. Press the key “Set” for some time to enter the state of adjusting time, and press the key “Set” to return to the mode of displaying temperature.

In the state of adjusting time, the hour part of the LED flashes, and you can adjust the hour by using the key “▲” and “▼”, then press the key “Set”, and the minute part of the LED flashes, you can also use the key “▲” and “▼” to adjust the value, then press the key “Set” again to exit. Pressing the key “M” in the adjusting process means giving up and exiting, but the time will not be saved.

5.6 How to heat manually

When displaying current temperature, the temperature is between “setting temperature – temperature difference” and “setting temperature + temperature difference”, the system may or not heat, here you press the key “▲” and hold it for 5 seconds, the controller will enter the heat manually when in the heat state, and stop heating when the temperature is above “setting temperature + temperature difference”.

5.7 Advanced Controlling

Press the key “M” and hold it for 5 seconds, and if you have set the password, the LED display the “PAS” to hint you to enter the password, you can use the key “↑” and “↓” to enter the password, if the password is correct, the LED will display the parameter code, use “↑” or “↓” to select the parameter code, Pressing the “set” key can make it to show the value of the parameter after select the parameter, here you use “↑” or “↓” to set the parameter (pressing the key and not release can add or minus rapidly), then press the “set” key to return to the state of showing parameter code after finishing setting. Pressing the key “M” can
Pressing the key “M” can exit the parameter setting state when display the parameter code, pressing the key “M” means cancel when in the process of setting parameter, and the parameter will not be changed.

5.8 Internal parameter code is shown below

Sort	Code	Parameter Name	Range	Factory setting	Unit	Remark
Temperature	F11	Setting temperature	F14 – F13	35	°C/°F	The setting range is limited by F13 and F14
	F12	Temperature difference	0.1 – 20	1.0	°C/°F	Control the temperature difference, please refer to the temperature controlling
	F13	Max setting temperature	-58 - 302	50	°C/°F	Notice: the controller will follow the rule of F14<F11<F13 forcibly, if you find out that one parameter can not be adjusted, it is because the parameter is limited by other parameters, you must first adjust other parameters
	F14	Min setting temperature	-58 – 302	10	°C/°F	
	F18	Evaporator sensor adjustment	-20 – 20	0.0	°C/°F	Adjust the outdoor machine sensor bias
	F19	Temp sensor adjustment	-20 – 20	0.0	°C/°F	Adjust the temperature sensor bias
Compressor	F21	Compressor delay time	0 -- 10	3	min	
	F29	Compressor controlling mode (temp controlling mode)	COOL / HEAT	HEAT	-	COOL: refrigeration mode HEAT: Heat mode
Defrosting	F31	Defrost start temperature	-20 – 80	-2	°C/°F	
	F32	Defrost end temperature	0 – 100	20	°C/°F	
	F33	Defrost start time	1 – 999	30	min	
	F34	Max defrost time	Off, 1 – 99	10	min	Off means no defrost
Water Pump	F40	Water Pump Select	0 – 1	1	-	0: water pump is not enable 1: water pump is enable
	F41	Water pump starts time before compressor starts	1 – 10	3	min	
	F42	Water pump stops time after compressor stops	0 – 10	3	min	
Alarm	F50	External alarm mode	0 -- 4	3	-	0: without external alarm 1: always open, unlocked 2: always open, locked 3: always closed, unlocked 4: always closed, locked
RTC	F60	Set the RTC time	00 : 00— 23 : 59	-	-	
	F61	Period 1 start time	00 : 00— 23 : 59 OFF	05 : 00	-	OFF means not using
	F62	Period 1 end time	00 : 00— 23 : 59 OFF	07 : 00	-	
	F63	Period 2 start time	00 : 00— 23 : 59 OFF	16 : 00	-	

	F64	Period 2 end time	00 : 00— 23 : 59 OFF	18 : 00	-	
	F65	Period 3 start time	00 : 00— 23 : 59 OFF	22 : 00	-	
	F66	Period 3 end time	00 : 00— 23 : 59 OFF	00 : 00	-	
	F69	Run Mode	0/1	0	-	0 : Automatic 1 : Economical
System setting	F80	Password	OFF 0001 -- 9999	OFF	-	OFF means no password 0000 means clearing password
	F81	Temperature unit	C/F	C	-	C: Centigrade F: Fahrenheit
	F85	Display accumulative running time	-	-	hour	
	F86	Accumulative running time reset	-	-	-	
	F87	Probation time	OFF 1 -- 9999	OFF	hour	The controller will stop if the accumulative time is over probation time, and show the alarm code "A99". OFF means no probation time
Testing	F98	Reserved				
	F99	Test self	This function can attract all relays in turn, and please don't use it when the controller is running!			
	End	Exit				

5.9 Basic Operating Principle

5.10 Temperature controlling

The controller has 2 temperature controlling modes: Refrigeration and Heat(F29). Temperature controlling point is controlled by "setting temperature (F11, or press the "set" key for some time to set)" and "temperature difference(F12)". In refrigeration mode (Valve is enable and follow compressor), the controller begins to refrigerate when the temperature of the temperature sensor is over "setting temperature + temperature difference", and it stops refrigerating when the temperature is under "setting temperature - temperature difference"; In heat mode (Valve is disable except when defrosting),

the controller begins to heat when the temperature of the temperature sensor is under “setting temperature – temperature difference”, and it stops heating when the temperature is over “setting temperature + temperature difference”.

5.11 Compressor delay time

The compressor delay time is set by F21, for example, 3 minutes. The controller contains a “compressor stop calculagraph”, and it begins to time when compressor stops, the program first checks the calculagraph before starting the compressor next time, the program will immediately start the compressor if the calculagraph reaches 3 minutes, if the calculagraph doesn’t reach 3 minutes, it will start again when the calculagraph reaches 3 minutes. Thus you can ensure that the start alternation is over 3 minutes after stopping, so as to prevent potential damage to the compressor as a result of frequent stopping and restarting. In addition, the controller doesn’t allow the compressor to start within 3 minutes after power supply power on, thus protecting the compressor in the event of power cut and then power on.

5.12 Auto defrosting principle

The controller first detects the temperature of unit when it begins to heat. If it is lower than “defrost start temperature”, the controller will first turn on defrosting, then turn on heating after defrosting ends. In addition, the controller will supervise the temperature of the unit when heating normally, and decide whether it needs to defrost according to the time spent in the continuous low temperature state. In other words, the defrosting calculagraph begins to time when the units temperature is lower than “defrost start temperature”, and turns on the defrosting when the value of time reaches “defrost start time”. The calculagraph will be cleared if the units temperature is higher than “defrost start temperature” when timing, and it begins to time again when the units temperature is lower than “defrost start temperature” next time. In other words, the value of defrosting calculagraph shows the continuous low temperature time of the unit.

The controller can check the defrosting effect with the temperature of the unit, if the temperature of unit goes up to the “defrost end temperature”, the controller will turn off the function of defrosting. If the defrosting time is above “max defrost time”, the controller will turn off defrosting forcibly.

The process above can only run in heating state, in other words, the controller will not turn on defrosting in non-heating state.

The Compressor and fan stop running when defrost starts, and the valve is enabled after 30 seconds, then after 5 seconds, compressor starts running and fan does not start.

Compressor stops running after defrost stops, and valve is disable after 30 seconds, then after 5 seconds, compressor and fan start running.

5.13 External alarm

The controller can connect a switching value, ie external alarm source (Pin 4, 5), when the external alarm occurs, the controller stops, displays the alarm code "A11". External alarm signal has 5 modes (F50):

The Alarm and code A11 will occur should water flow through the unit be insufficient or the unit is "powered up " with the water pump off.

5.14 Timer period functions and "Econ mode"

The controller contains a real time clock, and can time accurately. In "Econ Mode", the controller will control whether the unit needs to heat according to water temperature, and whether the current time is within the setting period of time, if it is not in the setting period of time, then the controller will not heat regardless of whether the water temperature is low and heating is required.

The controller can set a maximum of 3 heat periods at most, if you don't require some periods of the time periods, you can set the starting time and ending time as "OFF".

In addition, if the ending time is earlier than starting time, the controller considers this ending time is next day. For example, the period of time is "22:00"to"03:30", the controller considers it as 22:00 at night to 03:30 next day.

5.15 Probation time

A probation time can be set (F87), the controller can add up the running time after power is on, if the accumulative running time is over the probation time, the controller will stop and display the alarm code A99, if you want to eliminate the limit of probation time, set the F87 to "OFF", also you can use the F86 to clear the accumulative running time, and the unit can be operated normally again. The parameter F85 can be used to examine the accumulative running time of the controller (hour).

5.16 Password

In order to prevent unauthorized persons from changing the parameters, you can set a password (F80), and if you have set a password, the controller will “hint” you to enter the password after you press the key “M” for 5 seconds, you must enter the correct password, and then you can set / modify the parameters. If you don’t require the password, you can set F80 to “OFF”. IMPORTANT. The operator must remember the password, and if you forget the password, you cannot enter the setting mode.

6 Instructions and notices for installation

6.1 Materials Needed For Installation:

1. Plumbing connections(50mm OD) 40mm ID Adaptor kit supplied
2. Level surface for proper drainage;
3. Suitable electrical supply line. See rating plate on unit for Electrical specifications.

A junction box is not needed at the heat pump; connections are made inside of the heat pump electrical compartment. Conduit may be attached directly to the heat pump jacket.

4. Electrical isolation switch that will interrupt all power to the unit. This switch must be adjacent to the heat pump.
5. Watertight conduit to run the electrical supply line.
6. We recommends installing isolation valves and supplied MAC unions on the inlet and outlet water connections for ease of serviceability.

NOTE: Flex conduit is recommended for connecting the electrical supply wiring to the heat pump so that the front panel may be removed easily for servicing.

6.2 The requirements for heat pumps include the following

- 1, Appropriate site location and clearances;
- 2, sufficient air ventilation;
- 3, Proper electrical wiring;
- 4, Adequate water flow;

NOTE: This manual provides the information needed to meet the above requirements. Review all applicable and installation procedures completely before continuing the installation.

6.3 Clearances

Avoid placing the heat pump in locations where it can cause damage by water or condensate leakage. If this is not possible, provide a suitable drain pan to catch and divert any leakage. All criteria given in the following sections reflect minimum clearances. However, each installation must also be evaluated, taking into account the prevailing local conditions such as proximity and height of walls, and proximity to public access areas.

	Minimum Clearances for Operation	Recommended Clearances for Serviceability
A	15cm	60cm
B	15cm	30cm
C	15cm	30cm
lop	150cm	150cm

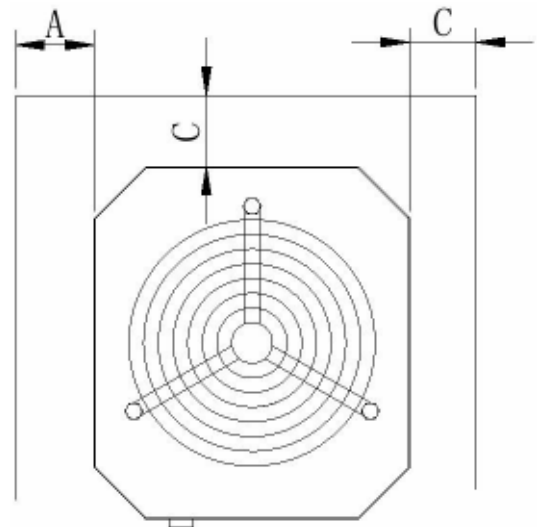

6.4 Equipment Location Pad

Place the heat pump on a flat surface, such as a concrete or fabricated slab (pad). This allows proper drainage of condensation and rain water from the base of the unit. If possible, the pad should be placed at the same level or slightly higher than the filter system equipment pad.

6.5 Installations

See Figure 1 (Standard plumbing Layout)

Figure 1

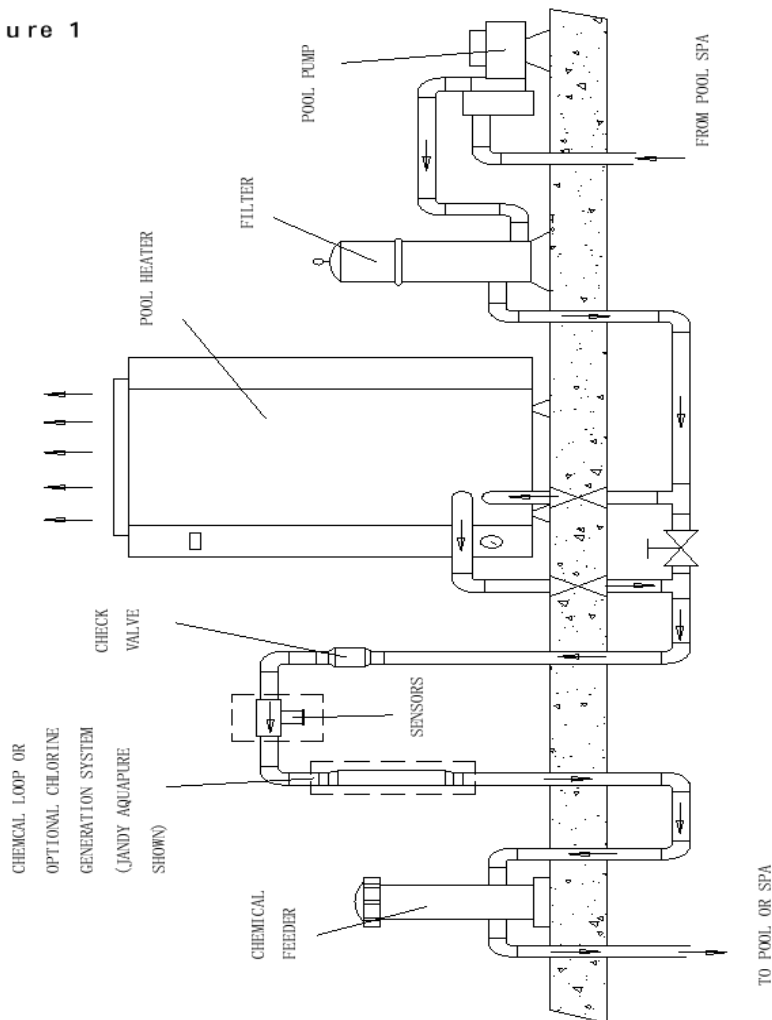

6.6 Condensation and Drainage

Condensation from the evaporator coil will occur while the unit is running and is dependent upon ambient air temperature and humidity. The more humid the ambient conditions the more condensation will be produced. For indoor installations, a means of condensate disposal must be provided. The drain hole in

the base of the heat pump is fitted with a 19mm diameter barbed adapter and route it to dispose of the condensate into a drain or outside of the building.

NOTE: It is important to remember that no part of the tubing or hose may be above the level of the drain hole in the base of the heat pump.

6.7 Flow pressure switch protection

The inlet/outlet header of the heat pump comes equipped with an internal automatic flow pressure switch. The automatic flow pressure switch ensures that the unit will only operate if the proper water flow through the heat pump is achieved. Insufficient water flow will cause the unit to automatically shut down and alarm "A11"

NOTE: Excess water flow will damage the heat exchanger.

6.8 Filtration System Layouts

6.8.1 Shared Filtration System

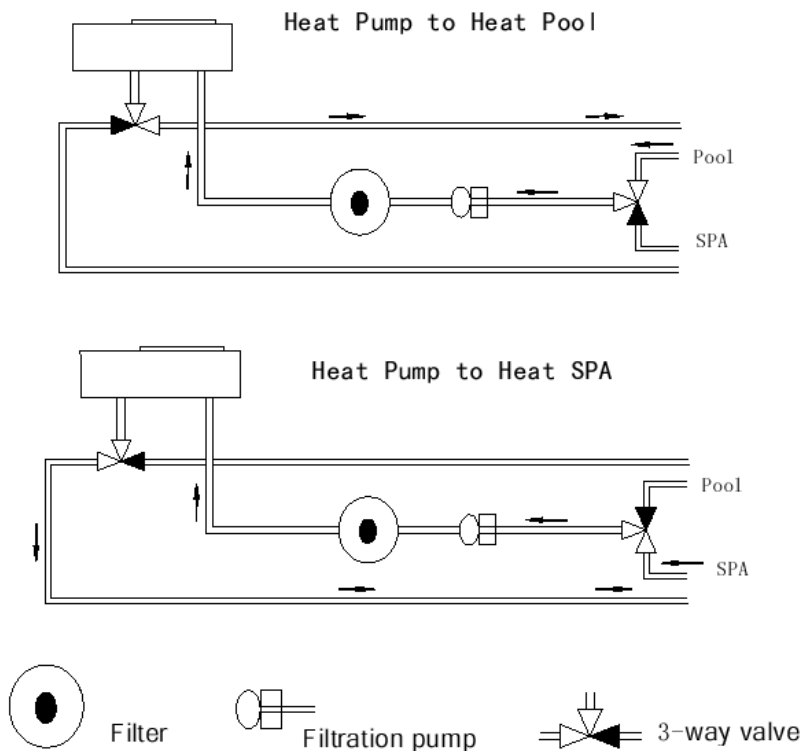

6. 6. 2 Independent Filtration System

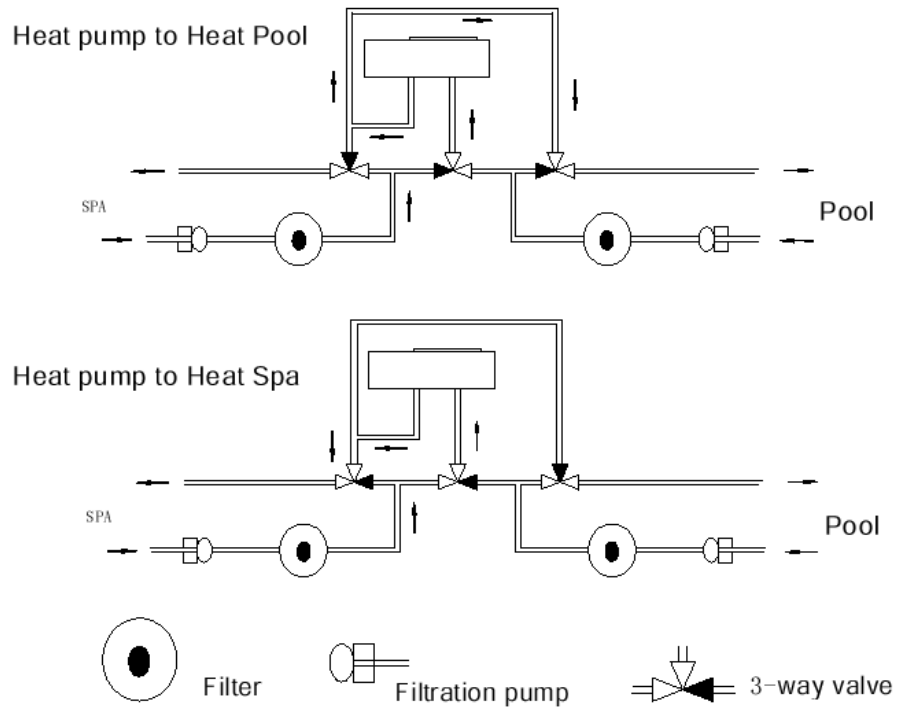

6.9 Multiple Heat Pump Connections

All Plumbing on multiple heat pump units must be done in parallel (see fig. 2 and fig.3))

Figure 2

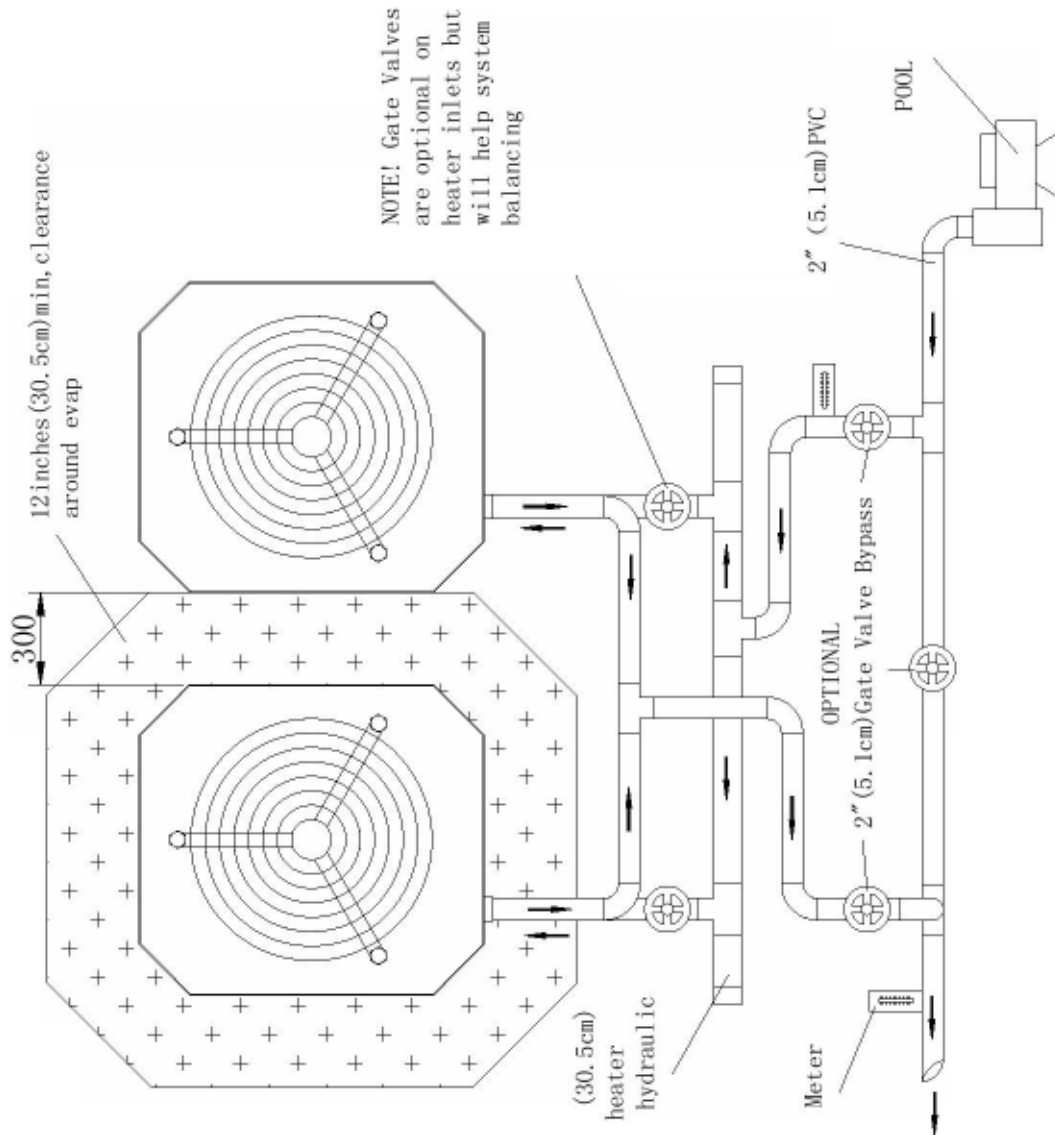

An equal flow of water to each heat pump is important for optimum operation.

Figure 3

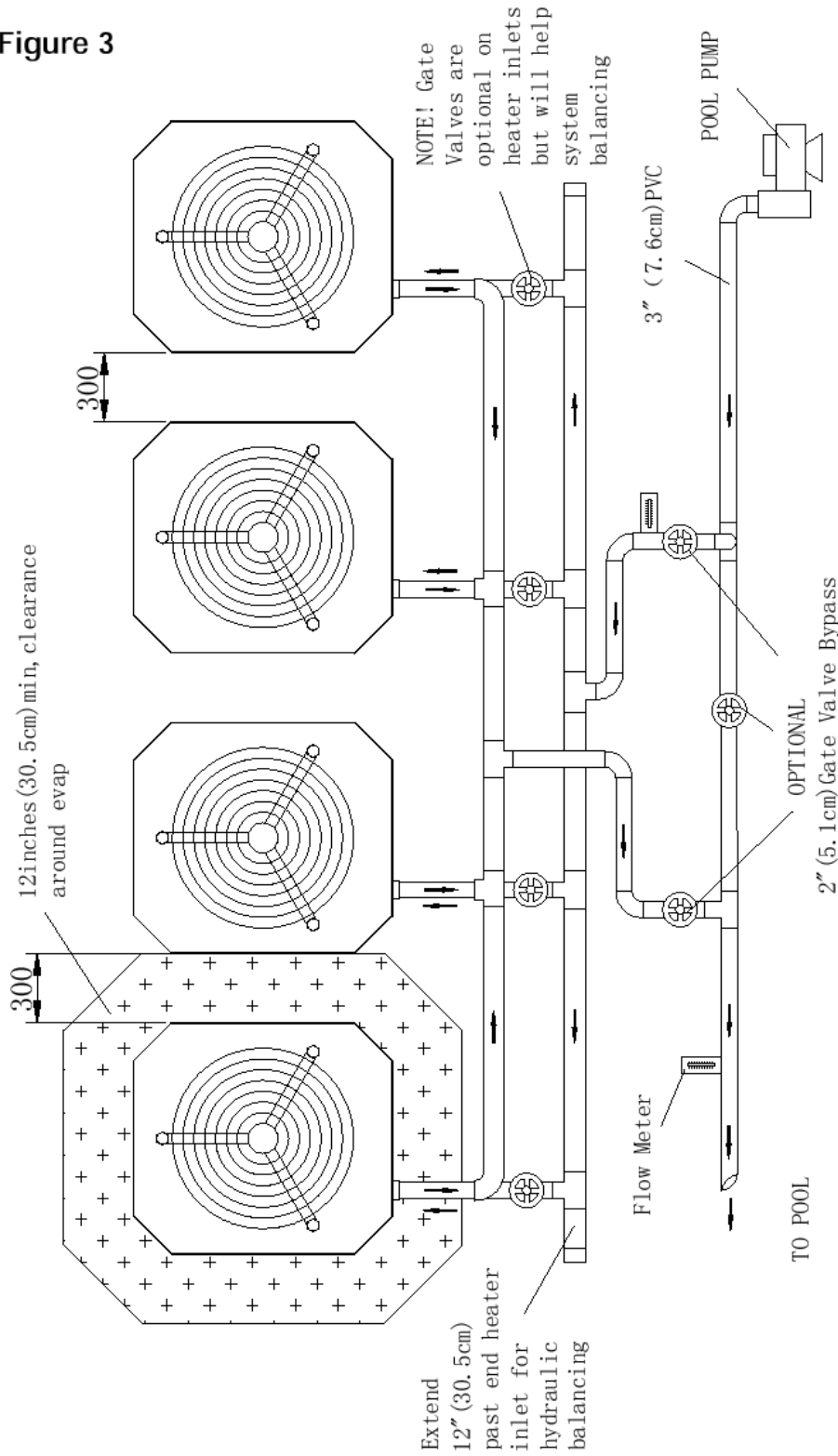

6. 10 Instructions and information for installation

NOTE: The pad on which the unit is installed must be sturdy and able to withstand its weight. If not, it is possible that the unit may fall off and be destroyed.

NOTE: The electrical system and installation must comply with the local regulations and rating data in the technical sheet.

NOTE: If installed in a tightly enclosed area, the unit will not operate efficiently and could be damaged.

NOTE: Incorrect voltage or power phase, will cause damage to the unit

NOTE: The unit must effectively grounded and be properly connected to the mains power supply by wiring of adequate size and by a suitably qualified professional.

NOTE: After the water pipe system is installed, the pipes must be washed and cleaned of any foreign material before connection to the heat pump unit / units.

NOTE: The pipe systems must be tested for compression resistance in order to check whether there is any leakage.

7.0 Safety Cautions

Attention: It is important that the pool water level is maintained and it is not allowed to drop to a low level.

Don't restart the unit again and again; you must wait 5 minutes before attempting to restart it.

If the hot water heat pump fails to operate, turn it off immediately.

If unit is not to be used for an extended period, it should be covered to keep out dust and foreign particles.

Please regularly clean the evaporator by professional means. If the unit has worked for a long time, there could be more dust in the evaporator coil, and the airflow volume will decrease. DO NOT use high pressure water cleaning system or water blaster.

To maintain efficiency, do not set the temperature too high or too low. Do not use unit near gas or diesel heaters, fires or in the vicinity of flammable liquids.

Do not insert fingers, foreign objects or items into the fan unit as it will cause injury.

Do not repair the unit yourself, please contact a suitably qualified technician when the unit displays error code.

Do not spray flammable chemicals around unit.

8.0 Trouble shooting and solutions

SYMPTOM	CORRECTIVE ACTION
Heat pump will not start, no control board display	Breaker or fuse may be tripped. Reset breaker or check fuse. If heat pump still does not run. call for service. Three-phase models only-The phases may be reversed or there may be a loss of phase, call for service.
Heat pump will not start, control board display working	Heat pump may be in delay count down of 3 minutes. Make sure control board thermostat is calling for the heater to come on (check setting on thermostat and temperature reading). Make sure heat pump is not in cooling mode.
Heat pump runs but does not heat	Verify cold air is blowing out the top of the heat pump. If the heat pump has just been installed or if the pool water has been allowed to cool significantly, it is necessary to run the heat pump continually, it is necessary to run the heat pump continually for 24-48 hours. If the heat pump has been in operation for some time, increase the circulating pump time, or switch the control board to Maintain Heat function. If heating a spa, verify no air intake stand pipes are open. If heat pump still does not heat, call for service.
Heat pump leaking water	Possible heat exchanger or plumbing leak. Turn the heat pump off, then turn circulating pump off for at least one hour to see if the water leak stops. If the water leak stops. normal condensation is occurring. If the water leak continues, after the heat pump is shut off for at least one hour, call for service.
Error code "A11" display in LED window	Insufficient water flow or no water flow through the unit whilst the unit is "powered up".

NOTICE TO INSTALLER

+ Install the Heat Pump on the water return side of the pool water pump, after the filtration system and prior to any chemical dispensing unit. It is recommended that a one way valve be installed to prevent any potential back flow of chemical into the Heat Pump when the pool water pump is switched off.

+ The Heat Pump should be wired so that it is on the same timed circuit as the existing pool water pump. This will ensure that the Heat Pump can only operate when the pool water pump is running and there is adequate water flow through the Heat Pump. The Heat Pump also has internal safety pressure switches which will disable the unit should the water flow be inadequate or fail, but these should not be used as a primary method of control. The unit will Alarm "A11" if water flow insufficient.

+ A switch should be installed so that the Heat Pump can be isolated from the circuit, allowing the pool water pump to continue to operate.

+ There is a built in 3 minute delay after powering up the Heat Pump before the compressor starts. During this time the unit will self-test all functions and the water flow rate. The fan may be operative.

+ Residual water should be drained from the Heat Pump and associated plumbing during long periods of non-use, over the winter months in cold regions to avoid water freezing in the unit and causing possible damage. The unit condenser, fan unit and its grill should be protected from snow build up.

+ The Heat Pump should be installed in an outside area where it is free from foliage, dirt, sand and other foreign objects and it should be firmly anchored on a level platform.

+ TO SET THE REQUIRED POOL TEMPERATURE. Press the key "set" for at least 2 seconds, the LED displays the required temperature, then using "↑" key or "↓" key to either increase or decrease the required temperature. After setting is complete, press "set" again, to exit the temperature setting mode. The display will return to showing the current pool temperature. Push the "↑" key or "↓" key momentarily to display required temperature.

+ For initial heat up each season it is recommended that the unit is adjusted to raise the temperature by 2 degrees per day. It is also recommended that the unit is run during the day only, this ensures maximum efficiency due to the higher ambient air temperature.

DO NOT attempt to raise cold water to your desired swimming temperature in one step.

This will cause the unit to run continuously which is outside the design parameters of the unit and may void the warranty.