



Installation and Operation Manual



MODEL: PHPM300 – PHPM800 series

Congratulations on the purchase of your Premier Heat Pumps swimming pool/Spa pool heat pump.

Our Heat Pumps are manufactured to the highest standards and quality, using high quality compressors, stainless steel cases and Titanium heat exchangers. It is important to read this instruction manual prior to installation and that it is retained for future reference.

Warning

RISK OF ELECTRICAL SHOCK OR ELECTROCUTION. The electrical supply to this product must be installed by a licensed or certified electrician in accordance with applicable national and local codes and ordinances. Improper installation may cause electrical hazard, which could result in death or serious injury to pool or spa users, installers or others, and may also cause damage to property. Read and follow the specific instructions inside this manual.

Contents

1~Working Principle and technical description	2
2~Main characteristics	2
3~Technical data	3
4~Electric circuit diagram	3
5~Operation instruction	4
6~Instructions and notices for installation	8
7~Safety Cautions	16
8~Troubleshooting and solutions	17

1.1, Technical Description

The swimming pool heat pump heater basically comprises a compressor, an evaporator, capillary or expanding valves and a condenser.

1.2, Working principle

Heat pumps use electricity to capture heat and move it from one place to another. They don't generate heat. As the pool pump circulates the swimming pool's water, the water drawn from the pool passes through the pool filter and the heat pump heater. The heat pump heater has a fan that draws in the outside air and directs it over the evaporator coil. The liquid refrigerant within the evaporator coil absorbs the heat from the ambient air and becomes a gas. The warm gas in the coil then passes through the compressor. The compressor increases the heat, creating a very hot gas that then passes through the condenser. The condenser transfers the heat from the hot gas to the cooler pool water circulating through the heater. The heated water then returns to the pool. The hot gas, as it flows through the condenser coil, returns to liquid form and travels back to the evaporator, where the whole process begins again.

1.3 Example of how a heat pump operates.

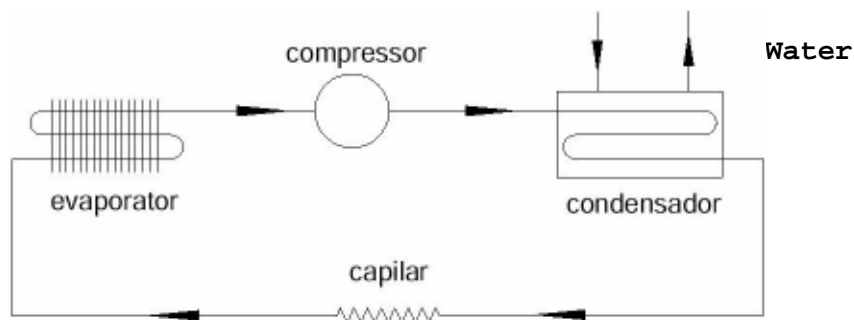

2. Main characteristics

2.1, Efficient and economical

The unit's Coefficient of Performance (cop) ~4.0 -5.0. In comparison, an electric boiler (cop) ~0.95, a gas or oil boiler (cop) is about 0.5 - 0.8, a coal-boiler (cop) is only about 0.3-0.7.

2.2, Safety ensured

When the unit is operating, all electrical parts are absolutely isolated from circulating water, thus avoiding any possible dangers

such as explosion, dry heating, gas poisoning, which can occur with a common diesel or gas water heater.

2.3, environmentally friendly

The applied refrigerant is not Freon, the refrigerant is either environmentally friendly R410a or R407C and when the unit is working, no waste water, no waste residue, no waste heat and no waste gas will pollute the environment.

2.4, Installation - convenient and simple

The heat pump can be installed in an outdoor area, balcony, flat roof or equipment room, and does not need purpose built room for installation.

2.5, modularized control function

Several units can be combined to make one hot water supply system controlled by modularization. The system can adjust the running time and order automatically, allowing the whole system to run efficiently, and every unit's total running time can be unified.

2.6, Operation is simple and convenient

The unit is controlled by microcomputer. According to the condition of water temperature and circular water volume, the unit will self adjust and there is no need for constant attention.

2.7, Automatic defrost function

With intelligent zed defrost function, you can set defrost condition according to different climates to make the unit defrost in a flexible way.

2.8, Far-ranging applicability

These units can be used in hotel, bath centre, school, factory, indoor pool facility etc.

3, Technical Data

MODEL	Heating Capacity	KW/hr	Power Input(w)	Stated Current	Power Input	Water Flow (min)
PHPM300	22000 btu/hr	6.5	1300	6.5	single phase	4m3/hr
PHPM600	47000	14.7	2800	14	single phase	7.5
PHPM700	64000	20.0	4000	18	single phase	10.0

4. Electric circuit diagram

4.1,

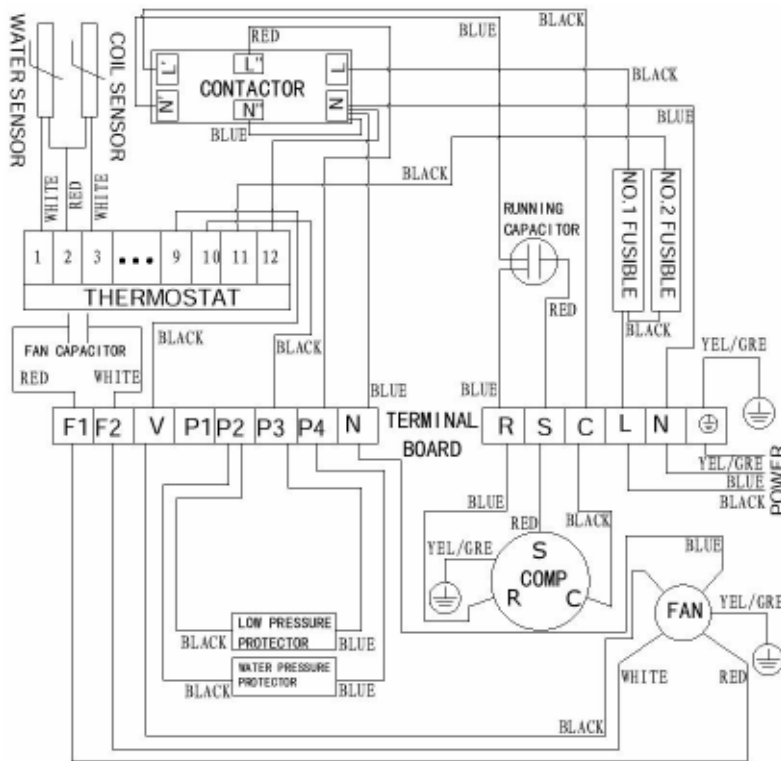

Ventilation and defrosting

5、 Operation instruction

5.1、 Control panel



Index Light	Name	Light	Flash
	Temp Setting	In the state of temp setting	-
	-	-	-
	Heat	Heating	Ready to heat, in the state of compressor start delay protection
	Defrost	Defrosting	Dripping or the state of compressor start delay protection
	-	-	-
	Alarm	-	Alarm state

5.2, Temperature controlling

The controller has 2 temperature controlling modes: Refrigeration and Heating(F29).Temperature controlling point is controlled by "setting temperature (P11, or press the "set" key for some time to set)" and "temperature difference(F12)". In refrigeration mode, the controller begins to refrigerate when the temperature of the temperature sensor is over "setting temperature + temperature difference", and it stops refrigerating when the temperature is under "setting temperature difference"; In heating mode, the controller begins to heat when the temperature of the

temperature sensor is under "setting temperature - temperature difference", and it stops heating when the temperature is over "setting temperature + temperature difference"

5.2.1 How to set the temperature

Press the key "set" for at least 2 seconds, then enter the state of temperature setting, here the LED displays the setting temperature, then using "↑" key or "↓" key can change the parameter (the key"↑" adds 0.10 C, the key"↓" minuses 0.10 C, press and hold it over 0.5 seconds can add or minus rapidly) . After setting, press "set" again, then exit the state of parameter setting. (The setting temp range is limited by the parameters P13 and P14, please refer to the senior operation).

Pressing the key "M" in the setting process means cancel and exit, but the setting value will not be saved.

When displaying current temperature, press "↓" key, Controller will display defrosting temperature. Loose "↓" key, then return to current temperature. Notice that if you press the key and hold it for 5 seconds, the controller will enter or exit the defrosting state forcibly.

5.2.2 Advanced Operation

Press the key "M" and hold it for 5 seconds, and if you have set the password, the LED display the "PAS" to hint you to enter the password, you can use the key "↑" and "↓" to enter the password, if the password is correct, the LED will display the parameter code, use "↑" or "↓" to select the parameter code, Pressing the "set" key can make it to show the value of the parameter after select the parameter, here you use "↑" or "↓" to set the parameter (pressing the key and not release can add or minus rapidly), then press the "set" key to return to the state of showing parameter code after finishing setting. Pressing the key "M" can exit the parameter setting state when display the parameter code, pressing the key "M" means cancel when in the process of setting parameter, and the parameter will not be changed.

5. 2.3, Internal parameter code is shown below

Sort	Code	Parameter	Range	Factory setting	Unit	Remark
Temperature	F11	Setting Temperature	F14-F13	35	°C	The setting is limited by F13 and F14
	F12	Temperature difference	0.1-20	1.0	°C	Control the temperature difference, please refer to temperature controlling
	F13	Max Temperature setting	-45-145	60	C	Note: The controller will follow the rule of F14<F11<F13 forcibly. If you find out that one parameter can not be adjusted, it is because the parameter is limited by the other parameters. The limiting parameters must be readjusted.
	F14	Min Temperature setting	-45-145	10	°C	
	F18	Evaporator adjustment	-20.0 to +20.0	0.0	°C	Adjust the evaporator bias
	F19	Temperature adjustment	-20.0 to +20.0	0.0	°C	Adjust the evaporator sensor bias
	Compressor	F21	Compressor delay time	0 - 10	3	min
Defrosting	F31	Defrost Time	1 to 999	3	min	
	F32	Defrost Temperature	0-50	-5	C	
	F33	Defrost end time	1 to 999	30	min	
	F34	Dripping time	0 to 99	5	min	
	F37	Defrost heat mode	0 or 1	0	-	0: electric heat;1 heat pump

Alarm	F50	External alarm mode	0 to - 4	0		0—without external alarm 1—always open unlocked 2—always open, locked 3—always closed, unlocked 4—always closed, locked
System setting	F80	Password	OFF 0001— 9999	OFF		OFF means no password 0000 means clearing password
	F85	Display accumulative running time			hour	
	F86	Accumulative running time reset			—	
	F87	probation time	OFF 1 to 9999	OFF	hour	The controller will stop if the accumulative time is over probation time and show the alarm code'A99 OFF means no probation time
Testing	F98	Reserved				
	F99	Test self	This function can attract all relays in turn and please do not use it when the controller is running.			
	End	Exit				

5.2.4, Auto defrosting principle

The controller first detects the temperature of outdoor machine when it begins to heat. If it is lower than "defrost start temperature", the controller will first turn on defrosting, then turn on heating after defrosting ends. In addition, the controller will supervise the temperature of outdoor machine when heating normally, and decide whether need to defrost according to the time of the outdoor machine in the continuous low temperature state. In other words, the defrosting calculagraph begins to time when the outdoor machine temperature is lower than "defrost start temperature", and turns on the defrosting when the value of time reaches "defrost start time". The calculagraph will be cleared if the outdoor machine temperature is higher than "defrost start temperature" when timing and it begins to time again when the outdoor machine temperature is lower than "defrost start temperature" next time. In other words, the value of defrosting

calculagraph shows the continuous low temperature time of the outdoor machine. The controller will turn on the compressor and cross valve after defrosting, and the heat pump is used for defrosting. The controller can check the defrosting effect with the temperature of outdoor machine, if the temperature of outdoor machine goes up to the "defrost end temperature", the controller will turn off the function of defrosting. If the defrosting time is above "max defrost time", the controller will turn off defrosting forcibly.

The process above can only run in heating state, in other words, the controller will not turn on defrosting in non-heating state.

6, Instructions and notices for installation

6.1 Materials Needed For Installation:

1. Plumbing connections (50mm OD) 40mm ID Adaptor kit supplied
2. Level surface for proper drainage;
3. Suitable electrical supply line. See rating plate on unit for Electrical specifications.

A junction box is not needed at the heat pump; connections are made inside of the heat pump electrical compartment. Conduit may be attached directly to the heat pump jacket.

4. Electric cut out (Disconnect) switch that will interrupt all power to the unit. This switch must be adjacent to the heat pump.

5. Watertight conduit to run the electrical supply line.

6. Recommends installing isolation valves on the inlet and outlet water connections for ease of serviceability.

NOTE: Flex conduit is recommended for connecting the electrical supply wires to the heat pump so that the front panel may be removed easily for servicing.

6.2 The requirements for heat pumps include the following

- 1, Appropriate site location and clearances;
- 2, sufficient air ventilation;
- 3, Proper electrical wiring;
- 4, Adequate water flow;

NOTE: This manual provides the information needed to meet these requirements. Review all application and installation procedures completely before continuing the installation.

6.3 Clearances

Avoid placing the heat pump in locations where it can cause damage by water or condensate leakage. If this is not possible, provide a suitable drain pan to catch and divert any leakage. All criteria given in the following sections reflect minimum clearances. However, each installation must also be evaluated, taking into account the prevailing local conditions such as proximity and height of walls, and proximity to public access areas.

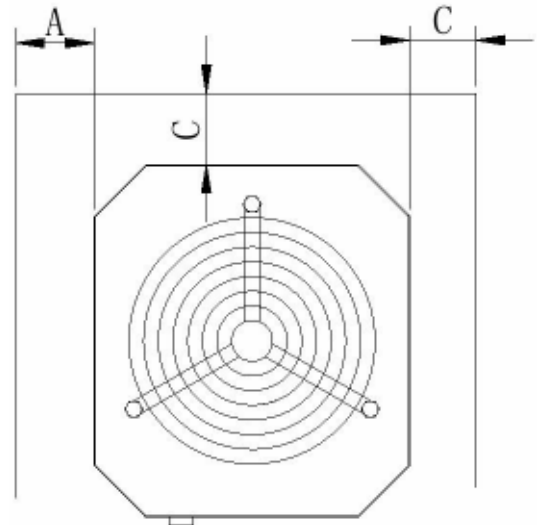

	Minimum Clearances for Operation	Recommended Clearances for Serviceability
A	15cm	60cm
B	15cm	30cm
C	15cm	30cm
lop	150cm	150cm

6.4 Equipment Location Pad

Place the heat pump on a flat surface, such as a concrete or fabricated slab (pad). This allows proper drainage of condensation and rain water from the base of the unit. If possible, the pad should be placed at the same level or slightly higher than the filter system equipment pad.

6.5 Indoor Installations

See Figure 1 (Standard plumbing Layout, Indoor)

Figure 1

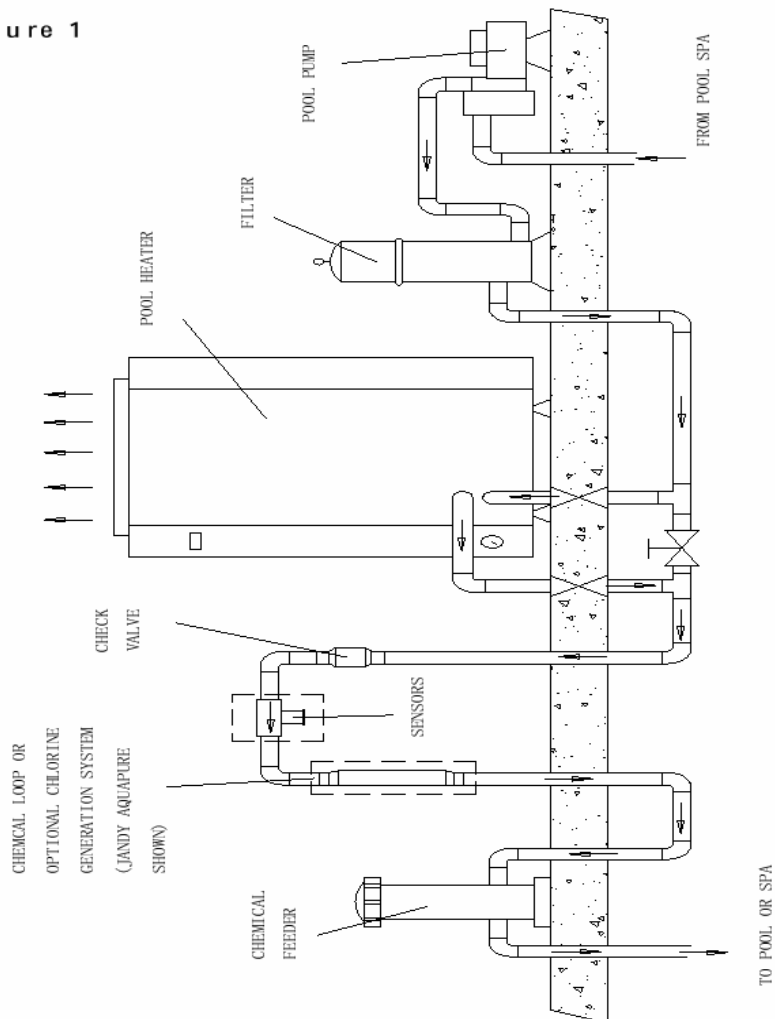

6. 5. Condensation and Drainage

Condensation from the evaporator coil will occur while the unit is running and is dependant upon ambient air temperature and humidity. The more humid the ambient conditions the more condensation will be produced. For indoor installations, a means of condensate disposal must be provided. The drain hole in the base of the heat pump is fitted with a 19mm diameter barbed adapter and route it to dispose of the condensate into a drain or outside of the building.

NOTE: It is important to remember that no part of the tubing or hose may be above the level of the drain hole in the base of the heat pump.

6.5.2 Check Valve Installation

The inlet/outlet header of the heat pump comes equipped with an internal automatic flow control valve. The automatic flow control valve maintains the proper flow through the heat pump.

NOTE: Excess water flow will damage the heat exchanger.

6.6 Filtration System Layouts

6.6.1 Shared Filtration System

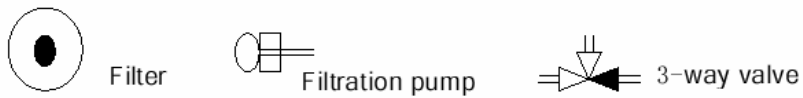
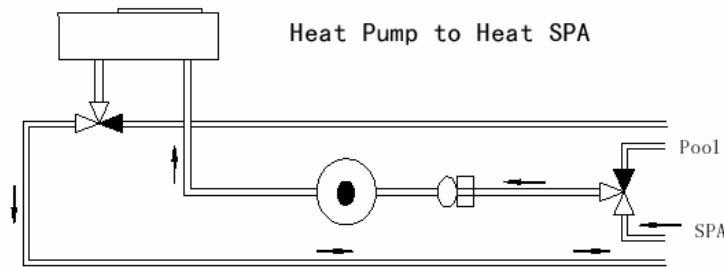
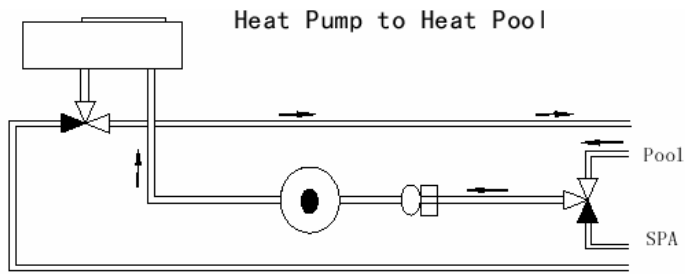

6.6.2 Independent Filtration System

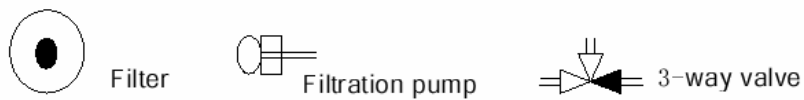
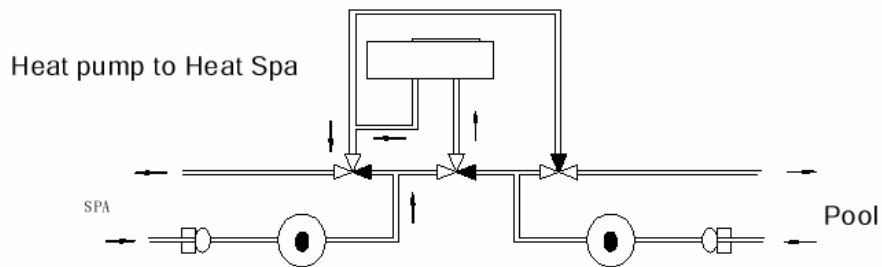
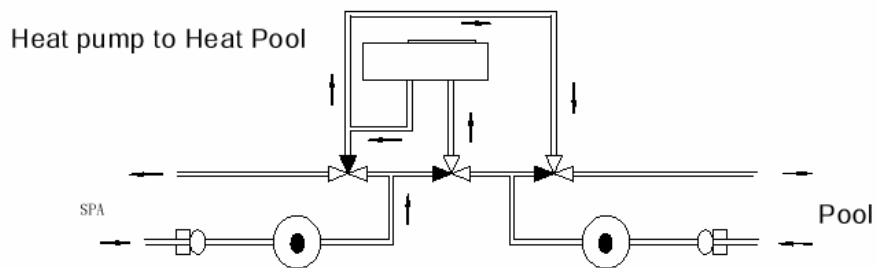

6.7 Multiple Heat Pump Connections

All Plumbing on multiple heat pump units must be done in parallel (see fig. 2 and fig.3))

Figure 2

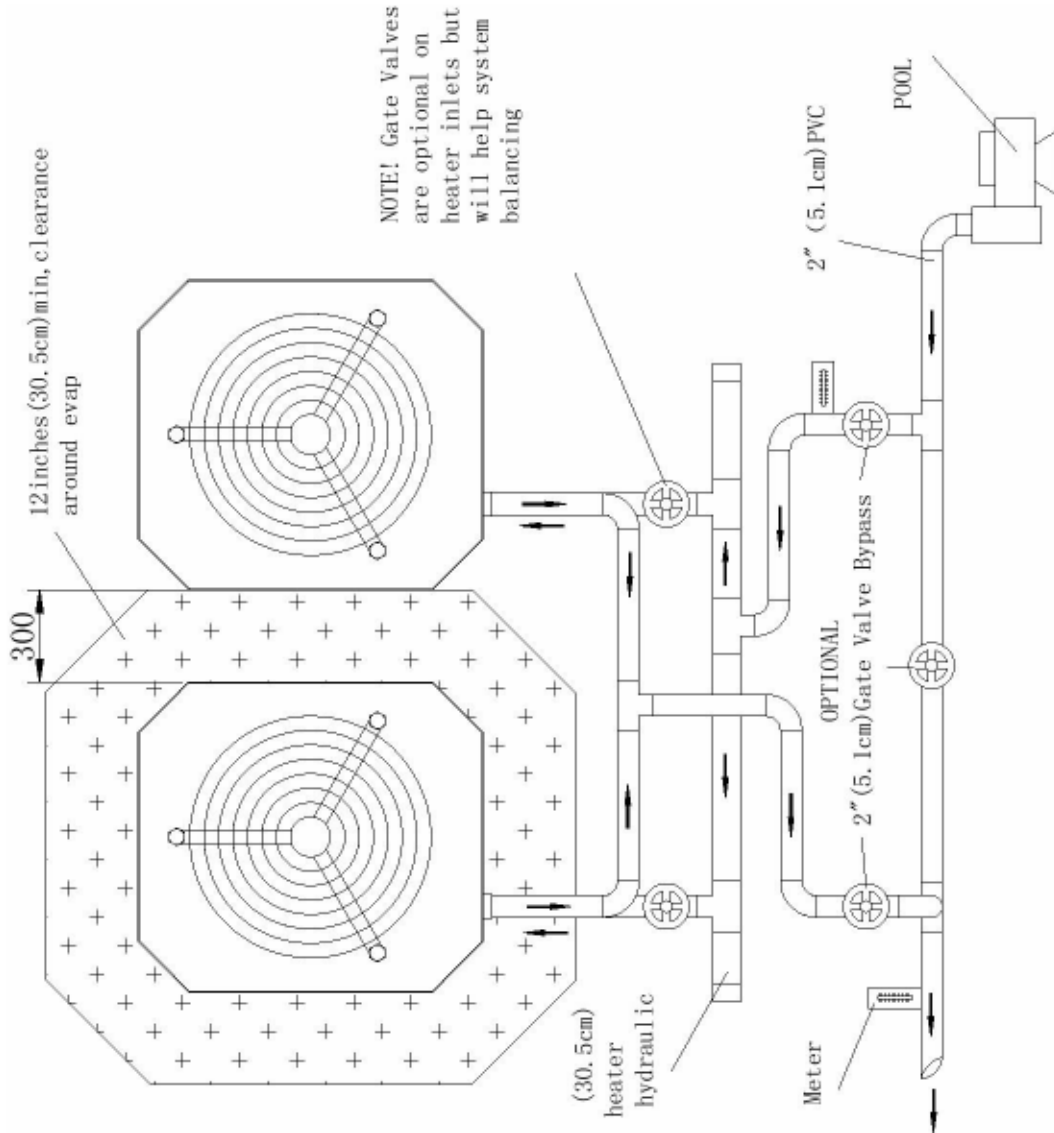

An equal flow of water to each heat pump is important for optimum operation.

Figure 3

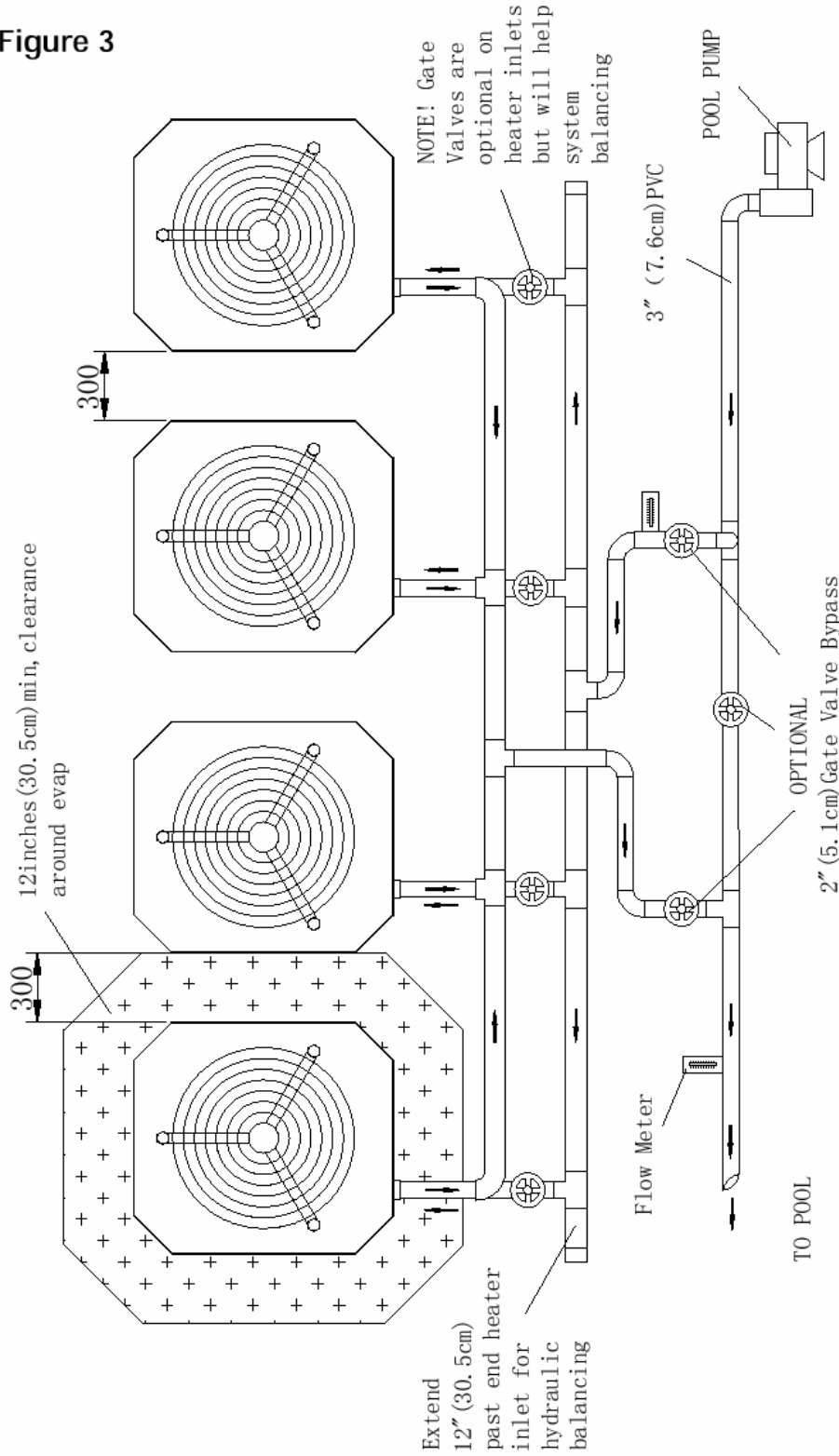

6. 8 Instructions and information for installation

NOTE: The pad on which the unit is installed must be sturdy and able to withstand its weight. If not, it is possible that the unit fall off and be destroyed.

NOTE: The electrical system and installation must comply with the local regulations and rating data in the technical sheet.

NOTE: If installed in a tightly enclosed area, the unit can not run well and could be damaged.

NOTE: Incorrect voltage or power phase, will cause damage to the unit

NOTE: The unit must effectively ground and be properly connected to the mains power supply by wiring of adequate size and by a suitably qualified professional.

NOTE: After the water pipe system is installed, the pipes must be washed and cleaned of any foreign material before connection to the heat pump unit / units.

NOTE: The pipe systems must be tested for compression resistance in order to check whether there is any leakage.

7, Safety Cautions

Attention: It is important that the pool water level is maintained and it is not allowed to drop to a low level.

Don't restart the unit again and again; you must wait 5 minutes before attempting to restart it.

If the hot heat water pump fails to operate, turn it off immediately.

If unit is not to be used for an extended period, it should be covered to keep out dust and foreign particles.

Please regularly clean the evaporator by professional means. If the unit has worked for a long time, there could be more dust in the evaporator coil, and the airflow volume will decrease. To have a comfortable efficiency, don't set the temperature too high or too low. Do not use unit near gas or diesel heaters, fires or in the vicinity of flammable liquids.

Do not insert fingers, foreign objects or items into the fan unit as it will cause injury.

Do not repair the unit yourself, please contact a suitably qualified technician when the unit displays error code.

Do not spray flammable chemicals around unit.

8.0 Trouble shooting and solutions

SYMPTOM	CORRECTIVE ACTION
Heat pump will not start, no control board display	Breaker or fuse may be tripped. Reset breaker or check fuse. If heat pump still does not run. call for service. Three-phase models only-The phases may be reversed or there may be a loss of phase, call for service.
Heat pump will not start,control board display working	Heat pump may be in delay count down of 3 minutes. Make sure control board thermostat is calling for the heater to come on(check setting on thermostat and temperature reading).Make sure heat pump is not in cooling mode.
Heat pump runs but does not heat	Verify cold air is blowing out the top of the heat pump. If the heat pump has just been installed or if the pool water has been allowed to cool significantly, it is necessary to run the heat pump continually, it is necessary to run the heat pump continually for 24-48 hours. If the heat pump has been in operation for some time, increase the circulating pump time, or switch the control board to Maintain Heat function. If heating a spa, verify no air intake stand pipes are open. If heat pump still does not heat, call for service.
Heat pump leaking water	Possible heat exchanger or plumbing leak.Turn the heat pump off, then turn circulating pump off for at least one hour to see if the water leak stops.If the water leak stops. normal condensation is occurring. If the water leak continues, after the heat pump is shut off for at least one hour, call for service.
Error code "A21" display in LED window	the water thermostat probe is broken (the temperature display "SHr" or "OPE") please contact the service or technician.
Error code "A22" display in LED window	the defrost probe is broken (the temperature display "SHr" or "OPE") please contact the service or technician.
Error code "A99" display in LED window	If you select test run time"F87",when the accumulative total time is over, error code "A99"display,the unit will refuse to work.
Error code "A99" display in LED window	Alarm from external alarm signal, please refer to the internal parameter code "F50"